

AULT **BUILT
FOR WORK.**

CATALOGUE

**MINING,
AGGREGATE
AND RECYCLE**



MCCLOSKEY

SUPERIOR

TERRACON

MWS

LIPPMANN



AULT

A BUSINESS BUILT FROM THE GROUND UP.

AULT is one of North America's best-performing equipment suppliers. For more than 15 years, we have been providing our customers with state-of-the-art equipment and the fastest, most efficient service possible.

We are an exclusive distributor of brands recognized as industry leaders: McCloskey International (with whom we have worked since our inception), Lippmann, MWS, Superior, Ecoverse and Terracon. For your project, we offer only the best. The best products supported by unrivalled service.

We don't just sell machines. We're a partner in your project. We're a part of your team.

This is our line of work.

Here's what we sell, what we maintain, what we support.

OUR PRODUCTS AND SERVICES ARE BUILT FOR WORK.



TABLE OF CONTENTS

EDITION 02/2026

4	PARTS AND SERVICE	88	LIPPMANN
6	WEAR PARTS	90	PORTABLE EQUIPMENT
8	MCCLOSKEY INTERNATIONAL	92	LJ3062 / LWM6042
10	JAW CRUSHERS	94	4800R
24	CONE CRUSHERS	98	LJ3447
32	IMPACT CRUSHERS	100	LJ3951
42	SCREENERS S-SERIES	102	SCREENS PLANT
52	SCALPERS R-SERIES	104	FIXED EQUIPMENT
62	CONVEYORS	108	SUPERIOR
70	TERRACON	110	CRUSHERS
72	4065T	118	FEEDERS / SCREENS
74	MWS	120	PORTABLE PLANTS
76	SCREW	130	WASHING
78	CSP	132	CONVEYORS
80	SANDSTORM	134	TELESTACKERS
84	AGGSTORM	136	SHIP LOADING
86	ULTRA FINES RECOVER	138	FUSION PLANT

SUPPORT AND SERVICE

HERE'S WHO YOU'LL BE WORKING WITH.
THIS IS OUR TEAM IN THE FIELD.

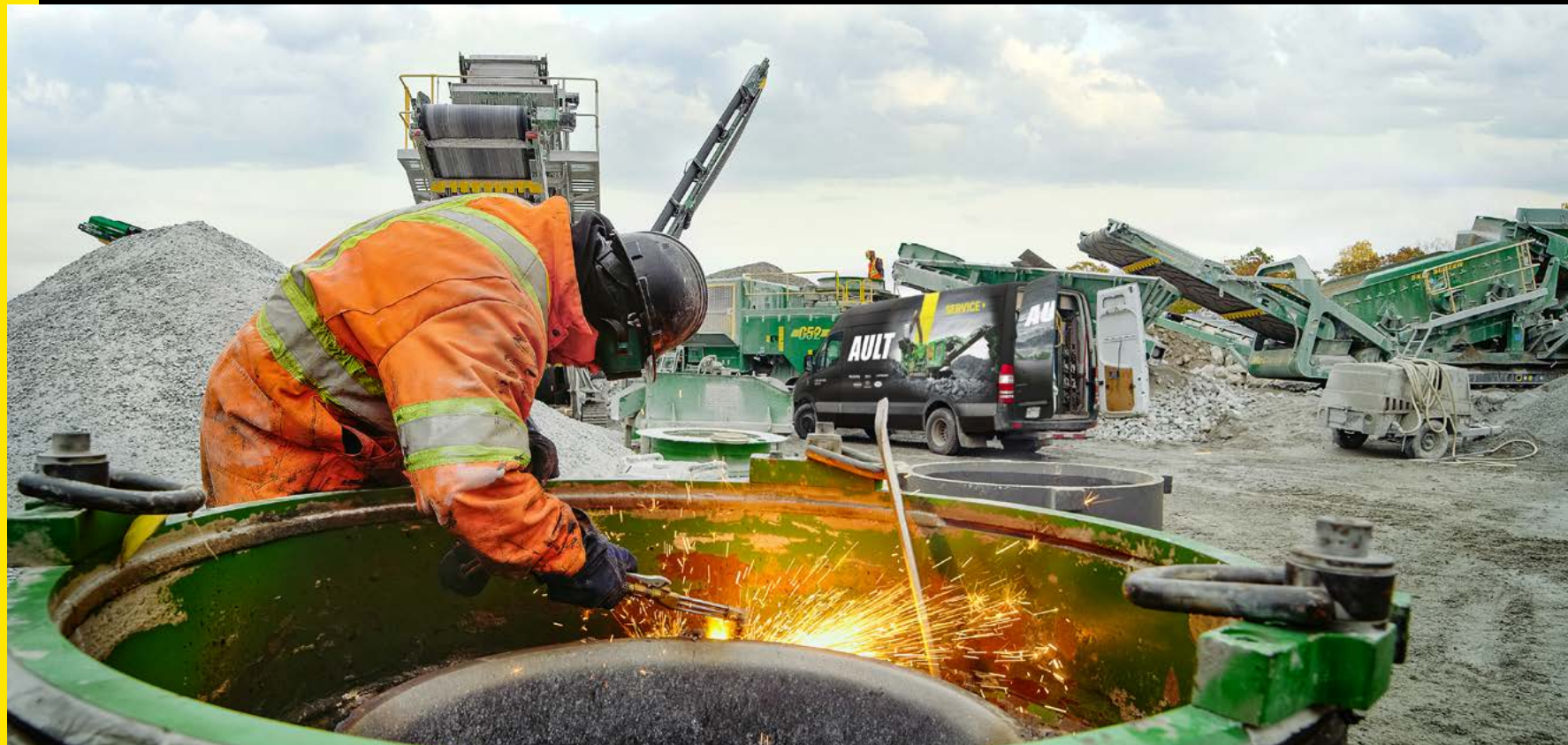

CONTACT OUR EXPERTS

1-855-300-AULT
info@ault.ca
www.ault.ca

AULT is a dedicated team of passionate experts.

Our advisors, engineers, and mechanics have been committed to the success of your projects and, ultimately, your business. Regardless of the challenge or the timeframe, you can rely on AULT's team across Ontario, Quebec, and the Maritimes to get the job done.

AULT's sole focus is our wide range of specialized processing equipment. Whether its mineral processing, quarries, pits, recycle, or composting, our team has the knowledge base and experience to help your operation run efficiently.

We make sure to maintain and support your equipment as if it were our own. By entrusting us with the maintenance and support of your equipment, you are assured that they will remain reliable, efficient, and long-lasting.

Our machines won't let you down, and our team will make sure of it.



WEAR PARTS

**BUILT TO LAST,
MADE TO PERFORM.**

At Ault, we provide the best parts to tackle the toughest conditions. Designed to endure and exceed your expectations, they deliver unmatched performance and reliability.

Each part is certified, tested, and ready to take on the challenges of your most demanding operations.

FIND YOUR PARTS

MATTHEW RESTOULE
Aftermarket Specialist
(514) 992-7155
matthew@ault.ca

WEAR PARTS

- *Jaw plates-inserted jaw plates, heavy-duty jaw plates*
- *Cheek plates*
- *Blow bars, curtain liners, wear plates*
- *Cone liners and mantles*

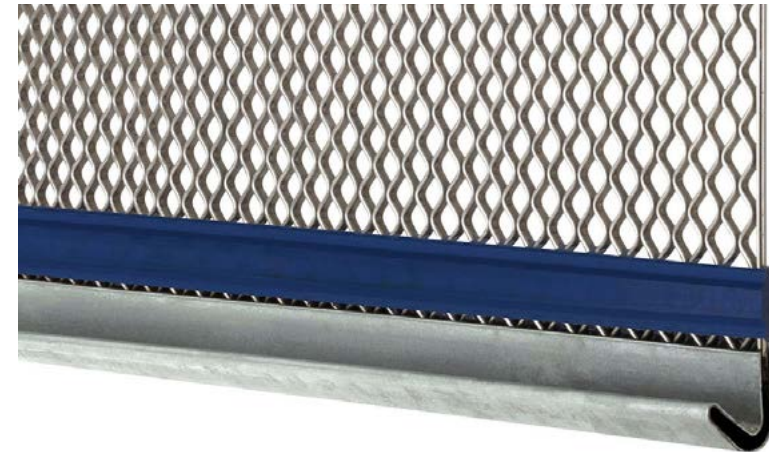

OTHER PARTS

- *Conveyors and stackers*
- *Shredders and grinders*
- *Windrow turners*
- *Belts and drive systems*
- *Hydraulic and adjustment components*
- *Magnetic liners*
- *Canoe liners*



SCREENS AND PLATES

- *Self-cleaning screens*
- *Woven wire*
- *Punch plates*
- *Finger deck assemblies*
- *Trommels drums and screens*
- *Rollers*
- *Scraper assemblies*



**FIELD TESTED
WORLDWIDE**



McCloskey
INTERNATIONAL

JAW CRUSHERS

McCloskey
INTERNATIONAL

Our selection of McCloskey Jaw Crushers are simply the best-performing on the market. Their easy-to-access mechanics make maintenance simple and fast. Approved for transportation in all provinces, they are robust and reliable and are sized for small to large projects. Exceptional productivity and unmatched durability.

J40 J45 J50 J4 J5 J6









J40

McCloskey
INTERNATIONAL

 POWER PACK	Volvo D8 (252 hp) / CAT C7 (225 hp)
 JAW	24" x 40" (610 mm x 1 010 mm)
 HOPPER	7.8 yd ³ (6 m ³)
 MAIN CONVEYOR	36" (900 mm)
 DISCHARGE HEIGHT	11' 6" (3.5 m)

TRANSPORTATION	
 WEIGHT	79 200 lbs (36 000 kg)
 LENGTH	45' 3" (13.8 m)
 WIDTH	8' 3" (2.5 m)
 HEIGHT	10' 6" (3.2 m)

SPECIFICATIONS

1 POWER PACK

- Volvo D8 (252 hp)
- optional**
- CAT C7 (225 hp)

2 FEED HOPPER

- Hopper extensions
- Grizzly bofar aperature 1 1/2"- 2 3/4" (38 mm - 70 mm)
- Hardox® 450 liner

3 JAW CRUSHER

- CSS adjust via hydraulic wedge
- Aggressive stroke
- Ultra-sonic jaw level sensor



4 MAIN CONVEYOR

- 3 ply flat belt
- Straight fines chute
- Discharge chute
- Stainless chute for overband magnet
- Hydraulic raise/lower
- Spring loaded poly belt cleaner
- Dust suppression system

optional

- 3-ply belt side discharge conveyoyr 26" (660 mm)
- Overband magnet on main conveyoyr (twin pole)
- Manual variable speed control on main conveyoyr

OTHER FEATURES

- Removeable track control c/w cable (complete with start/stop feeder)
- Wireless communication
- 4 hydraulic leveling legs
- Open access chassis

optional

- Working lights
- Safety beacon lights





ADDITIONAL INFORMATION







J45

McCloskey
INTERNATIONAL

 POWER PACK	Volvo D11 (360 hp) / CAT C9 (350 hp)
 JAW	27" x 45" (680 mm x 1 140 mm)
 HOPPER	8 yd ³ (6 m ³)
 MAIN CONVEYOR	42" (1 060 mm)
 DISCHARGE HEIGHT	13' (3.9 m)

TRANSPORTATION	
 WEIGHT	103 400 lbs (47 000 kg)
 LENGTH	47' 6" (14.5 m)
 WIDTH	8' 2" (2.5 m)
 HEIGHT	11' 2" (3.4 m)

SPECIFICATIONS

1 POWER PACK

- Volvo D11 (360 hp)
- optional**
- CAT C9 (350 hp)

2 FEED HOPPER

- Hopper extensions
- Grizzly bofar aperature 1 1/2" - 2 3/4" (38 mm x 70 mm)

pre-screen (option)

- Panfeeder with double-deck pre-screen
- Pre-screen bofar bars aperture 1" - 2" (25 mm - 50 mm)
- Pre-screen bofar bars aperture 1 1/2" - 2 3/4" (38 mm - 70 mm)

3 JAW CRUSHER

- CSS adjust via hydraulic wedge
- Aggressive stroke
- Ultra-sonic jaw level sensor



4 MAIN CONVEYOR

- 3 ply flat belt
- Straight fines chute
- Discharge chute
- Stainless chute for overband magnet
- Hydraulic raise/lower
- Spring loaded poly belt cleaner
- Dust suppression system

optional

- 3 ply side discharge conveyor 26" (600 mm)
- Overband magnet (twin pole)
- Manual variable speed control

OTHER FEATURES

- Removeable track control c/w cable (complete with start/stop feeder)
- Wireless communication
- 4 hydraulic leveling legs
- Open access chassis

optional

- Working lights
- Safety beacon lights





ADDITIONAL INFORMATION









J50

McCloskey
INTERNATIONAL

 POWER PACK	Volvo D11 (360 hp) / CAT C9 (350 hp)
 JAW	29" x 50" (730 mm x 1 300 mm)
 HOPPER	8.2 yd ³ (6.3 m ³)
 MAIN CONVEYOR	48" (1 200 mm)
 DISCHARGE HEIGHT	14' (4.2 m)

TRANSPORTATION	
 WEIGHT	111 100 lbs (50 500 kg)
 LENGTH	48' 11" (14.9 m)
 WIDTH	9' 10" (3.0 m)
 HEIGHT	11' 5" (3.5 m)

SPECIFICATIONS

1 POWER PACK

- Volvo D11 (360 hp)
- Twin oil coolers

optional

- CAT C9 (350 hp)

2 FEED HOPPER

- Hopper extensions
- Feeder bofar bars aperature 1 1/2" - 2 3/4" (38 mm - 70 mm)

pre-screen (option)

- Panfeeder with double-deck pre-screen
- Pre-screen bofar bars aperture 1" - 2" (25 mm - 50 mm)
- Pre-screen bofar bars aperture 1 1/2" - 2 3/4" (38 mm - 70 mm)

3 JAW CRUSHER

- CSS adjust via hydraulic wedge
- Aggressive stroke
- Ultra-sonic jaw level sensor

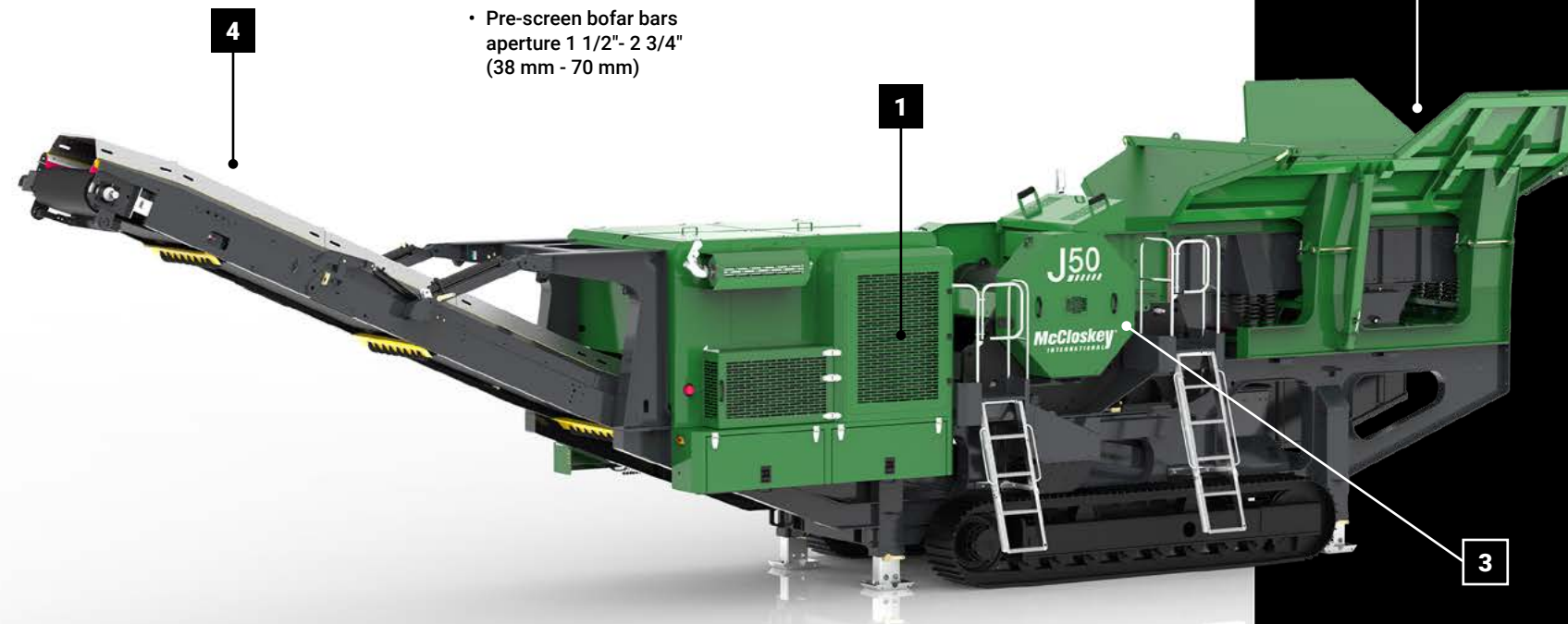

4 MAIN CONVEYOR

- 3 ply flat belt
- Straight fines chute
- Stainless chute for overband magnet
- Hydraulic raise/lower
- Discharge chute
- Spring loaded poly belt cleaner
- Dust suppression system

optional

- 3 ply side discharge conveyor (26")
- Overband magnet (twin pole)
- Manual variable speed control

OTHER FEATURES

- Removeable track control c/w cable (complete with start/stop feeder)
- Wireless communication
- 4 hydraulic leveling legs
- Open access chassis

optional

- Working lights
- Safety beacon lights





ADDITIONAL INFORMATION









J4

McCloskey
INTERNATIONAL

 POWER PACK	Volvo D11 (360 hp) / CAT C9 (350 hp)
 JAW	28" x 42" (700 mm x 1 060 mm)
 HOPPER	8 yd ³ (6 m ³)
 MAIN CONVEYOR	48" (1 200 mm)
 DISCHARGE HEIGHT	13' (3.9 m)

TRANSPORTATION	
 WEIGHT	111 000 lbs (50 000 kg)
 LENGTH	48' 11" (14.9 m)
 WIDTH	9' 10" (3.0 m)
 HEIGHT	11' 5" (3.5 m)

SPECIFICATIONS

1 POWER PACK

- Volvo D11 (360 hp)
- optional**
- CAT C9.3B (350 hp)

2 FEED HOPPER

- Hopper extensions
- Grizzly aperture 2" – 5" (50 mm – 130 mm)

pre-screen (option)

- Panfeeder with double-deck pre-screen

3 JAW CRUSHER

- Metso mine duty crusher
- CSS adjust via hydraulic wedge.
- Ultra-sonic jaw level sensor



4 MAIN CONVEYOR

- 3 ply flat belt
- Straight fines chute
- Stainless chute for overband magnet
- Hydraulic raise/lower
- Spring loaded urethane scraper
- Dust suppression system

optional

- Side discharge conveyor 26" (600 mm)
- Hydraulic raise / lower overband magnet
- Manual variable speed control

OTHER FEATURES

- Removeable track control c/w cable (complete with start/stop feeder)
- Wireless communication
- 4 hydraulic leveling legs
- Wish bone style chassis
- 2x side access to engine bay





ADDITIONAL INFORMATION









J5

McCloskey
INTERNATIONAL

 POWER PACK	Volvo D11 (360 hp) / CAT C9B (415 hp)
 JAW	30" x 45" (760 mm x 1 150 mm)
 HOPPER	8.9 yd ³ (6.8 m ³)
 MAIN CONVEYOR	55" (1 400 mm)
 DISCHARGE HEIGHT	13' 11" (4.2 m)

TRANSPORTATION	
 WEIGHT	132 000 lbs (60 000 kg)
 LENGTH	53' 9" (16.4 m)
 WIDTH	10' 2" (3.1 m)
 HEIGHT	11' 10" (3.6 m)

SPECIFICATIONS

1 POWER PACK

- Volvo D11 (360 hp)
- optional**
- CAT C9.3B (415 hp)

2 FEED HOPPER

- Hopper extensions
- Grizzly aperture 2" – 5" (50 mm – 130 mm)
- pre-screen (option)**
- Panfeeder with double-deck pre-screen

3 JAW CRUSHER

- Metso mine duty crusher
- CSS adjust via hydraulic wedge.
- Ultra-sonic jaw level sensor



4 MAIN CONVEYOR

- 3 ply flat belt
- Straight fines chute
- Stainless chute for overband magnet
- Hydraulic raise / lower
- Discharge chute
- Spring loaded urethane scraper
- Dust suppression system

optional

- Side discharge conveyor 32" (600 mm)
- Hydraulic raise / lower overband magnet
- Manual variable speed control

OTHER FEATURES

- Removeable track control c/w cable (complete with start/stop feeder)
- Wireless communication
- 4 hydraulic leveling legs
- Wish bone style chassis
- 2x side access to engine bay





ADDITIONAL INFORMATION









J6

McCloskey
INTERNATIONAL

 POWER PACK	Volvo D13 (510 hp) / CAT C13B (516 hp)
 JAW	34" x 47" (865 mm x 1 200 mm)
 HOPPER	9 yd ³ (7 m ³)
 MAIN CONVEYOR	55" (1 400 mm)
 DISCHARGE HEIGHT	17' (5.2 m)

TRANSPORTATION	
 WEIGHT	160 000 lbs (72 700 kg)
 LENGTH	58' 11" (18 m)
 WIDTH	10' 2" (3.1 m)
 HEIGHT	12' 9" (3.9 m)

- 1 POWER PACK**
- Volvo D13 (510 hp)
 - optional**
 - CAT C13b (516 hp)

- 2 FEED HOPPER**
- Hopper extensions
 - Grizzly aperture 2" – 5" (50 mm – 130 mm)
 - pre-screen (option)**
 - Panfeeder with double-deck pre-screen

- 3 JAW CRUSHER**
- Metso mine duty crusher
 - CSS adjust via hydraulic wedge.
 - Ultra-sonic jaw level sensor



- 4 MAIN CONVEYOR**
- 3 ply flat belt
 - Straight fines chute
 - Stainless chute for overband magnet
 - Hydraulic raise / lower
 - Discharge chute
 - Spring loaded urethane scraper
 - Dust suppression system

- optional**
- Side discharge conveyor 32" (600 mm)
 - Hydraulic raise / lower overband magnet
 - Manual variable speed control

- OTHER FEATURES**
- Removeable track control c/w cable (complete with start/stop feeder)
 - Wireless communication
 - 4 hydraulic leveling legs
 - Wish bone style chassis
 - 2x side access to engine bay

SPECIFICATIONS

ADDITIONAL INFORMATION



CONE CRUSHERS

McCloskey
INTERNATIONAL

In partnership with Metso, our range of cone crushers has more power than ever before and are distinguished by its unmatched lifespan and reliability. Combining the world's most famous cone with the world's most useable track chassis, our cone crushers offer a more profitable solution for your business.





C2c C3 C4









C2c

McCloskey
INTERNATIONAL

 POWER PACK	Volvo D11 (360 hp) / CAT C9 (350 hp)
 CONE	200 HP
 FEEDER	7.4 yd ³ (5.4 m ³)
 MAIN CONVEYOR	48" (1 220 mm)
 DISCHARGE HEIGHT	12' 9" (3.9 m)

TRANSPORTATION	
 WEIGHT	106 770 lbs (40 500 kg)
 LENGTH	54' 5" (16.6 m)
 WIDTH	9' 2" (2.8 m)
 HEIGHT	11' 2" (3.4 m)

SPECIFICATIONS

1 POWER PACK

- Volvo D11 (360 hp)
- Refueling transfer pump

optional

- CAT C9 (350 hp)

2 FEED HOPPER

- Hardox® 450 liner
- Metal detector on feeder
- Multi-angle adjustment
- Intelligent feed control
- 3 ply flat belt 48" (1 220 mm)

optional

- Hopper extensions
- Hopper bridge

3 CONE CRUSHER

- Head diameter 37" (940 mm)
- Feed opening 7" (178 mm)
- Production max 275 STPH
- Ultra-sonic level detector



4 MAIN CONVEYOR

- 3 ply - 48" (1 220 mm)
- Discharge chute
- Spring loaded poly belt cleaner
- Access hatch
- Dust suppression system

optional

- Long conveyor 48" (1 220 mm) discharge height 14' 6" (4.4 m)

5 RECIRCULATION SYSTEM (OPTION)

- 5' x 12' double deck closed-circuit screening system

OTHER FEATURES

- Spring loaded poly belt cleaner
- Removeable track control c/w cable
- Start / stop feeder

optional

- Working lights
- Safety beacon lights





ADDITIONAL INFORMATION









C3

McCloskey
INTERNATIONAL

 POWER PACK	Volvo D13 (510 hp) / CAT C13B (516 hp)
 CONE	300 HP
 FEEDER	8.1 yd ³ (6.2 m ³)
 MAIN CONVEYOR	48" (1 220 mm)
 DISCHARGE HEIGHT	12' 9" (3.9 m)

TRANSPORTATION	
 WEIGHT	111 100 lbs (50 500 kg)
 LENGTH	57' 4" (17.5 m)
 WIDTH	10' 4" (3.1 m)
 HEIGHT	11' 10" (3.6 m)

SPECIFICATIONS

1 POWER PACK

- Volvo D13 (510 hp)
- Refueling transfer pump

optional

- CAT C13B (516 hp)

2 FEED HOPPER

- Hardox® 450 liner
- Metal detector on feeder
- Multi-angle adjustment
- Intelligent feed control
- 3 ply flat belt 48" (1 220 mm)

optional

- Hopper extensions
- Hopper bridge

3 CONE CRUSHER

- Head diameter 44" (1 120 mm)
- Feed opening 9 1/2" (242 mm)
- Production max - 485 STPH
- Ultra-sonic level detector



4 MAIN CONVEYOR

- 3 ply - 48" (1 220 mm)
- Discharge chute
- Spring loaded poly belt cleaner
- Access hatch
- Dust suppression system

optional

- Long conveyor 48" (1 220 mm) discharge height 14' 6" (4.4 m)

5 RECIRCULATION SYSTEM (OPTION)

- Double deck closed-circuit screening system 6' x 14' (1.8 m x 4.3 m)

OTHER FEATURES

- Spring loaded poly belt cleaner
- Removeable track control c/w cable
- Start/stop feeder

optional

- Working lights
- Safety beacon lights





ADDITIONAL INFORMATION









C4

McCloskey
INTERNATIONAL

 POWER PACK	Volvo D16 (615 hp) / CAT C18 (600 hp)
 CONE	400 HP
 FEEDER	8.1 yd ³ (6.2 m ³)
 MAIN CONVEYOR	48" (1 220 mm)
 DISCHARGE HEIGHT	12' 9" (3.9 m)

TRANSPORTATION	
 WEIGHT	123 458 lbs (56 000 kg)
 LENGTH	55' 3" (16.8 m)
 WIDTH	12' (3.7 m)
 HEIGHT	11' 10" (3.6 m)

SPECIFICATIONS

1 POWER PACK

- Volvo D16 (615 hp)
- Refueling transfer pump

optional

- CAT C18 (600 hp)

2 FEED HOPPER

- Hardox® 450 liner
- Metal detector on feeder
- Multi-angle adjustment
- Intelligent feed control
- 3 ply flat belt 48" (1 220 mm)

optional

- Hopper extensions
- Hopper bridge

3 CONE CRUSHER

- Head diameter 52" (1 320 mm)
- Feed opening 12" (305 mm)
- Production max - 700 STPH
- Ultra-sonic level detector

4 MAIN CONVEYOR

- 3 ply - 48" (1 220 mm)
- Discharge chute
- Spring loaded poly belt cleaner
- Access hatch
- Dust suppression system

optional

- Long conveyor discharge height 14' 6" (4.4 m)

OTHER FEATURES

- Spring loaded poly belt cleaner
- Removeable track control c/w cable
- Start / stop feeder

optional

- Working lights
- Safety beacon lights



ADDITIONAL INFORMATION



IMPACT CRUSHERS

Whether for primary or secondary crushing of natural material or recycling, our three models of impact crushers are among the most versatile.

I3c I4cR I44v3R I54

McCloskey
INTERNATIONAL













I3c

McCloskey

INTERNATIONAL

	POWER PACK	Volvo D8 (252 hp)
	IMPACT ROTOR	34" x 32" (864 mm x 813 mm)
	HOPPER	3.6 yd ³ (2.6 m ³)
	MAIN CONVEYOR	36" (900 mm)
	DISCHARGE HEIGHT	9' 10" (3.0 m)

TRANSPORTATION

	WEIGHT	60 627 lbs (27 500 kg)
	LENGTH	42' 9" (13.0 m)
	WIDTH	8' 2" (2.5 m)
	HEIGHT	9' 9" (2.9 m)

1 POWER PACK

- Volvo D8 (252 hp)

2 FEED HOPPER

- Hardox® 450 liner
- Bofar aperture
1 3/8" - 2 9/16"
(35 mm - 65 mm)

optional

- Blanking plates over bofar deck

3 IMPACT CRUSHER

- 4 bar impact rotor
34" x 32"
(864 mm x 813 mm)
- Multi-function adjustable impact apron
- Variety of hammer compositions

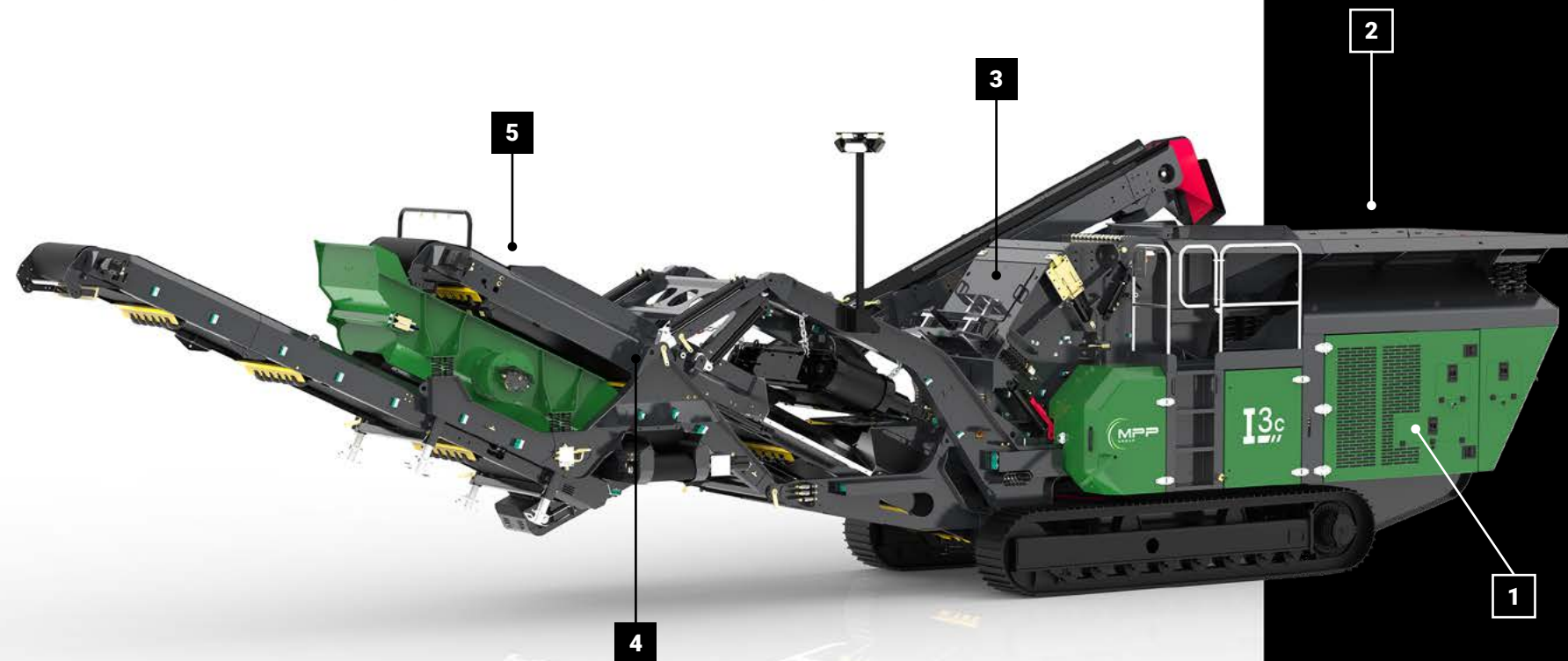

4 MAIN CONVEYOR

- 3 ply flat belt
36" (914 mm)
- Straight fines chute
- Discharge chute
- Spring loaded poly belt cleaner
- Dust suppression system

optional

- Overband magnet on main conveyor (twin pole)

5 RECIRCULATION SYSTEM

- Single deck closed-circuit screening system
3' 7" x 6' 7" (1 m x 2 m)

OTHER FEATURES

- Manual jib hoist
- Removeable track control c/w cable

optional

- Side discharge conveyor 3-ply belt
20" (508 mm)
- Working lights
- Safety beacon lights

SPECIFICATIONS





ADDITIONAL INFORMATION









I4cR

McCloskey
INTERNATIONAL

 POWER PACK	CAT 9.3 (375 hp)
 IMPACT ROTOR	45" x 41" (1.1 m x 1 m)
 HOPPER	7.4 yd ³ (5.4 m ³)
 MAIN CONVEYOR	48" (1.2 m)
 DISCHARGE HEIGHT	10' 6" (3.2 m)

TRANSPORTATION

 WEIGHT	91 500 lbs (41 500 kg)
 LENGTH	51' 10" (15.8 m)
 WIDTH	9' 10" (3.0 m)
 HEIGHT	10' 6" (3.2 m)

1 POWER PACK

- CAT 9.3 (375 hp)

2 FEED HOPPER

- Hardox® 450 liner
- Bofar aperture 1 3/8" 2 9/16" (35 mm - 65 mm)

optional

- Blanking plates over bofar deck

3 IMPACT CRUSHER

- 4 bar impact rotor 45" x 41" (1.1 m x 1 m)
- Multi-function adjustable impact arms
- Variety of hammer compositions

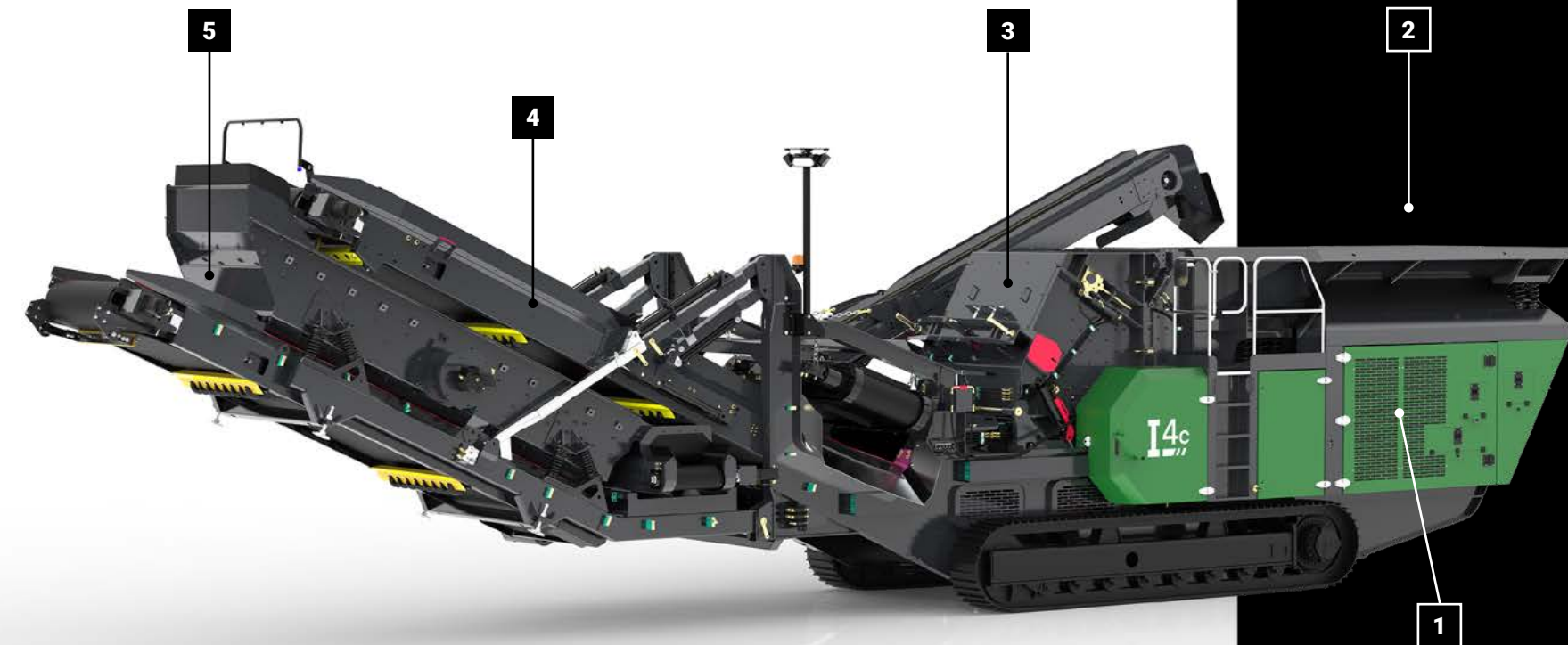

4 MAIN CONVEYOR

- 3 ply flat belt - 48" (1.2 m) Discharge chute
- Straight fines chute
- Discharge chute
- Spring loaded poly belt cleaner
- Dust suppression system

optional

- Overband magnet on main conveyor (twin pole)

5 RECIRCULATION SYSTEM

- Single deck closed-circuit screening system 5' x 12' (1.5 m x 3.6 m)

OTHER FEATURES

- Manual jib hoist
- Removeable track control c/w cable

optional

- Side discharge conveyor 3-ply belt 24" (610 mm)
- Working lights
- Safety beacon lights

SPECIFICATIONS





ADDITIONAL INFORMATION





I44v3R

McCloskey
INTERNATIONAL

 POWER PACK	Volvo D11 (360 hp) / CAT C9 (350hp)
 IMPACT ROTOR	44" x 43" (1.1 m x 1 m)
 HOPPER	7.8 yd ³ (6 m ³)
 MAIN CONVEYOR	48" (1.2 m)
 DISCHARGE HEIGHT	13' 9" (4.2 m)

TRANSPORTATION

 WEIGHT	133 000 lbs (60 000 kg)
 LENGTH	59' 5" (18.1 m)
 WIDTH	11' 4" (3.5 m)
 HEIGHT	11' 10" (3.6 m)

1 POWER PACK

- Volvo D11 (360 hp)

optional

- CAT C9 (350 hp)

2 FEED HOPPER

- Hardox® 450 liner
- Full length pan feeder with Grizzly

optional

- Blanking plates over bofar deck
- Panfeeder with double-deck pre-screen

3 IMPACT CRUSHER

- 4 bar impact rotor 44" x 43" (1.1 m x 1 m)
- Hydraulic adjustable 2 apron system
- Variety of hammer compositions

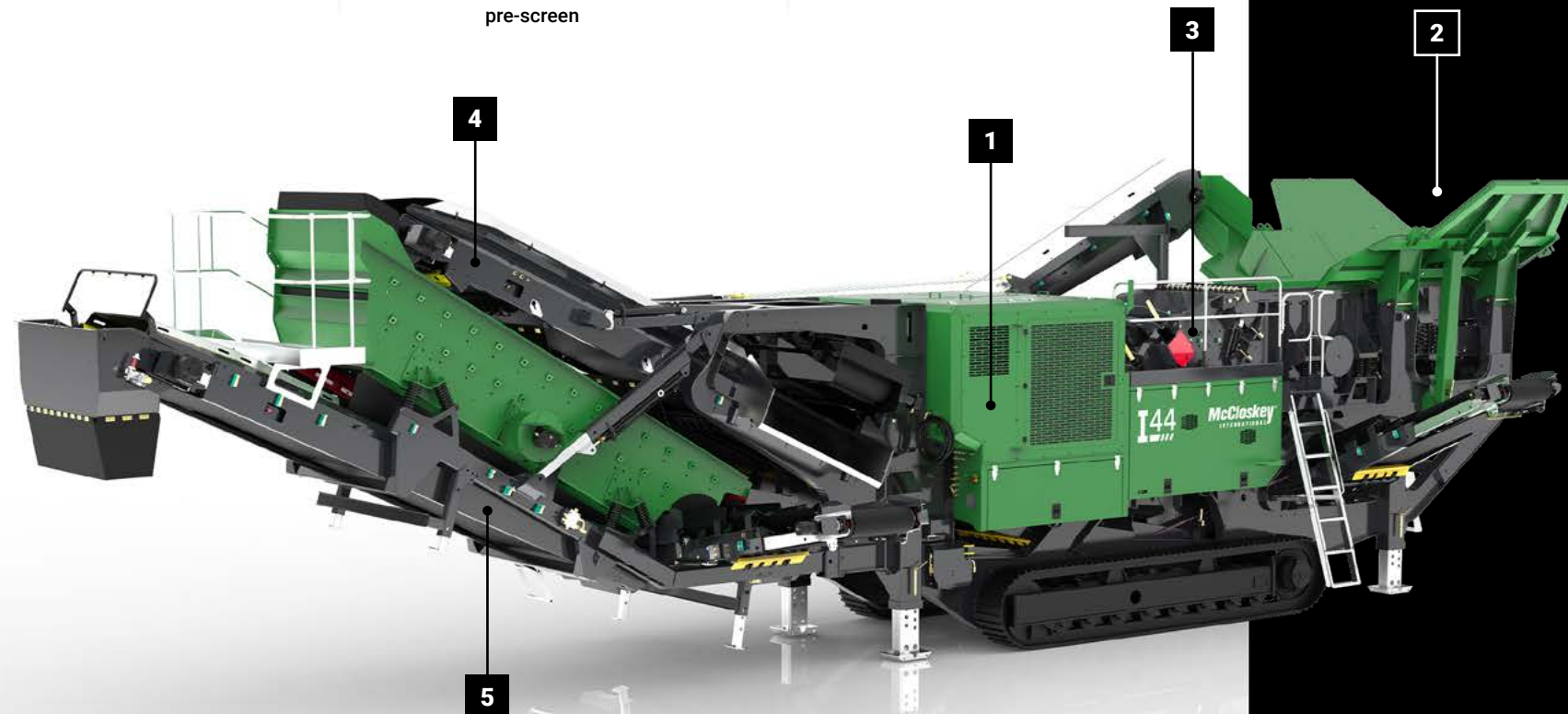

4 MAIN CONVEYOR

- 3 ply flat belt - 48" (1.2 m)
- Straight fines chute
- Discharge chute
- Spring loaded poly belt cleaner
- Dust suppression system

optional

- Overband magnet on main conveyor (twin pole)
- Vibrating under-pan feeder

5 RECIRCULATION SYSTEM

- Deck-and-a-half recirculating system 6' x 14' (1.8 m x 4.3 m)
- Double deck recirculating system 6' x 14' (1.8 m x 4.3 m)

OTHER FEATURES

- Manual jib hoist
- Removeable track control c/w cable

optional

- Side discharge conveyor 3-ply belt 20" (508 mm)
- Working lights
- Safety beacon lights

SPECIFICATIONS





ADDITIONAL INFORMATION









I54

McCloskey
INTERNATIONAL

 POWER PACK	Volvo D13 (510 hp) / CAT C13B (516 hp)
 IMPACT ROTOR	54" x 48" (1.3 m x 1.2 m)
 HOPPER	8.3 yd ³ (6.8 m ³)
 MAIN CONVEYOR	55" (1.4 m)
 DISCHARGE HEIGHT	13' 9" (4.2 m)

TRANSPORTATION	
 WEIGHT	111 100 lbs (50 500 kg)
 LENGTH	52' (15.6 m)
 WIDTH	9' 10" (3.0 m)
 HEIGHT	11' 10" (3.6 m)

1 POWER PACK

- Volvo D13 (510 hp)
- optional**
- CAT C13B (516 hp)

2 FEED HOPPER

- Hardox® 450 liner
- Full length pan feeder with Grizzly
- Grizzly aperture 2" – 5" (50 mm – 130 mm)
- optional**
- Blanking plates over bofar deck 4' x 8' (1.2 m x 4.2 m)

3 IMPACT CRUSHER

- 4 bar impact rotor 54" x 48" (1.3 m x 1.2 m)
- Hydraulic adjustable 2 apron system
- Variety of hammer compositions



4 MAIN CONVEYOR

- 3 ply flat belt - 55" (1.4 m)
- Straight fines chute
- Discharge chute
- Spring loaded poly belt cleaner
- Dust suppression system

optional

- Overband magnet o main conveyor (twin pole)
- Vibrating under-pan feeder

5 RECIRCULATION SYSTEM (OPTION)

- Deck-and-a-half recirculating system 6' x 14' (1.8 m x 4.3 m)
- Double deck recirculating system 6' x 14' (1.8 m x 4.3 m)

OTHER FEATURES

- Manual jib hoist
- Removeable track control c/w cable
- optional**
- Side discharge conveyor 3-ply belt 32" (810 mm)
- Working lights
- Safety beacon lights

SPECIFICATIONS

ADDITIONAL INFORMATION



SCREENERS S-SERIES

McCloskey
INTERNATIONAL

Our high-energy screenbox is unstoppable. The S-Series has proven itself as the best in the market. Available with two or three decks (2DT or 3DT) and highly adjustable screen box angle our S-Series screeners will leave you impressed.





S130 S190 S250 S275









S130



-  **POWER PACK** CAT C4.4 (100 hp) / Deutz 3.6 (100 hp)
-  **SCREEN BOX** 5' x 14' (1.5 m x 4.3 m)
-  **HOPPER** 15 yd³ (11.5 m³)
-  **SIDE DISCHARGE** 15' 1" (4.6 m)
-  **FINES DISCHARGE** 15' 4" (4.6 m)

- TRANSPORTATION**
-  **WEIGHT** 63 933 lbs (29 000 kg)
-  **LENGTH** 54' 2" (16.5 m)
-  **WIDTH** 9' 6" (2.9 m)
-  **HEIGHT** 11' 2" (3.4 m)

1 POWER PACK

- CAT C4.4 (100 hp)
- optional**
- Deutz 3.6 (100 hp)
- Dual power electric and diesel hydraulic
- Auxiliary drive circuit (PTO)

2 FEED HOPPER

- 15 yd³ (11.5 m³) feed hopper with 18' (5.5 m) full length grid
- Wireless remote coffin bar tipping grid Spacing 4" (102 mm)

optional

- Single deck livehead in place of grid Spill plate included
- Double deck livehead in place of grid Spillplate included
- 15' (4.6 m) feeding hopper Grid with crusher chute
- 1/4" (6 mm) wear plate Hardox® 450 liner and chutes
- Adjustable hopper door
- Adjustable coffin bar spacing
- Spill plate for tipping grid



3 CONVEYORS

- Independent pump sections for each conveyor
- Flat belt feed conveyor 48" (1 200 mm)
- Chevron belt on main conveyor 42" (1 000 mm)
- Chevron belt side conveyors 26" (660 mm)
- Flat belt tail conveyor with discharge chute 48" (1 200 mm)

optional

- Dust covers - main & tail conveyor
- Tail conveyor discharge chute & spray bar

4 SCREEN BOX

- High-Energy™ screenbox 5' x 14' (1.5 m x 4.3 m)

optional

- 3-Deck configuration with blending option shuttle conveyor

OTHER FEATURES

- Remote machine shut off
- Removeable track control C/W cable
- Tipping grid remote (TGR)

optional

- Single shaft shredder
- Working lights
- Fitted safety beacons

SPECIFICATIONS





ADDITIONAL INFORMATION









S190

McCloskey
INTERNATIONAL

 POWER PACK	CAT C4.4 (134 hp) / Deutz 3.6 (134 hp)
 SCREEN BOX	5' x 20' (1.5 m x 6 m)
 HOPPER	15 yd ³ (11.5 m ³)
 SIDE DISCHARGE	16' 9" (5.2 m)
 FINES DISCHARGE	15' 3" (4.6 m)

TRANSPORTATION	
 WEIGHT	83 600 lbs (38 000 kg)
 LENGTH	60' 6" (18.5 m)
 WIDTH	9' 6" (2.9 m)
 HEIGHT	11' 2" (3.4 m)

1 POWER PACK

- CAT C4.4 (134 hp)
- optional**
- Deutz 3.6 (134 hp)
- Dual power electric and diesel hydraulic
- Auxiliary drive circuit (PTO)

2 FEED HOPPER

- 15 yd³ (11.5 m³) feed hopper with 18' (5.5 m) full length grid
- Wireless remote coffin bar tipping grid Spacing 4" (102 mm)

optional

- Single deck livehead in place of grid Spill plate included
- Double deck livehead in place of grid Spillplate included
- 15' (4.6 m) feeding hopper Grid with crusher chute
- 1/4" (6 mm) wear plate Hardox[®] 450 liner and chutes
- Adjustable hopper door
- Adjustable coffin bar spacing
- Spill plate for tipping grid



3 CONVEYORS

- Independent pump sections for each conveyor
- Flat belt feed conveyor 48" (1 200 mm)
- Chevron belt on main conveyor 42" (1 000 mm)
- Chevron belt side conveyors 32" (810 mm)
- Flat belt tail conveyor with discharge chute 48" (1 200 mm)

optional

- Dust covers - main & tail conveyor
- Tail conveyor discharge chute & spray bar

4 SCREEN BOX

- High-Energy™ screenbox 5' x 20' (1.5 m x 6 m)

optional

- 3-Deck configuration with blending option shuttle conveyor

OTHER FEATURES

- Remote machine shut off
- Removeable track control C/W cable
- Tipping grid remote (TGR)

optional

- Single shaft shredder
- Working lights
- Fitted safety beacons

SPECIFICATIONS





ADDITIONAL INFORMATION









S250



 POWER PACK	Volvo D5 (218 hp) / CAT C7 (225 hp)
 SCREEN BOX	6' x 22' (1.8 m x 6.7 m)
 HOPPER	15 yd ³ (11.5 m ³)
 SIDE DISCHARGE	17' 9" (5.4 m)
 FINES DISCHARGE	16' 6" (5 m)

TRANSPORTATION	
 WEIGHT	95 700 lbs (42 500 kg)
 LENGTH	64' 2" (19 m)
 WIDTH	12' (3.6 m)
 HEIGHT	11' 10" (3.6 m)

1 POWER PACK

- Volvo D5 (218 hp)
- optional**
- CAT C7 (225 hp)
- Dual power electric and diesel hydraulic
- Auxiliary drive circuit (PTO)

2 FEED HOPPER

- 15 yd³ (11.5 m³) feed hopper with 18' (5.5 m) full length grid
- Wireless remote coffin bar tipping grid Spacing 4" (100 mm)
- optional**
- Single deck livehead in place of grid Spill plate included
- Double deck livehead in place of grid Spillplate included
- 15' (4.6 m) feeding hopper Grid with crusher chute
- 1/4" (6 mm) wear plate Hardox® 450 liner and chutes
- Adjustable hopper door
- Adjustable coffin bar spacing
- Spill plate for tipping grid

3 CONVEYORS

- Independent pump sections for each conveyor
- Flat belt feed conveyor 48" (1 200 mm)
- Chevron belt on main conveyor 48" (1 200 mm)
- Chevron belt side conveyors 36" (910 mm)
- Flat belt tail conveyor with discharge chute 48" (1 200 mm)
- optional**
- Dust covers main & tail conveyor
- Tail conveyor discharge chute & spray bar

4 SCREEN BOX

- High-Energy™ screenbox 6' x 22' (1.8 m x 6.7 m)
- optional**
- 3-Deck configuration with blending option shuttle conveyor

OTHER FEATURES

- Remote machine shut off
- Removeable track control C/W cable
- Tipping grid remote (TGR)
- optional**
- Single shaft shredder
- Working lights
- Fitted safety beacons



SPECIFICATIONS







ADDITIONAL INFORMATION









S275

McCloskey
INTERNATIONAL

 POWER PACK	CAT C7.1 (225 hp) / Volvo D5 (218 hp)
 SCREEN BOX	Dual 6' x 12' (3.6 m x 1.8 m)
 HOPPER	15 yd ³ (11.5 m ³)
 FINES DISCHARGE	16' 5" (5 m)
 SIDE DISCHARGE	17' 9" (5.4 m)
 RADIAL DISCHARGE	15' 10" (4.8 m)

TRANSPORTATION	
 WEIGHT	93 540 lbs (42 430 kg)
 LENGTH	64' 2" (19 m)
 WIDTH	12' 2" (3.75 m)
 HEIGHT	11' 10" (3.6 m)

1 POWER PACK

- CAT C7.1 (225 hp)

optional

- Volvo D5 (218 hp)
- Dual power electric and diesel hydraulic
- Auxiliary drive circuit (PTO)
- Diesel fired cold weather package (CAT)

2 FEED HOPPER

- 15 yd³ (11.5 m³) feed hopper with 18' (5.5 m) full length grid
- Wireless remote coffin bar tipping grid Spacing 4" (100 mm)

optional

- Single deck livehead in place of grid Spill plate included
- Double deck livehead in place of grid Spillplate included
- 15' (4.6 m) feeding hopper Grid with crusher chute
- 1/4" (6 mm) wear plate Hardox® 450 liner and chutes
- Adjustable hopper door
- Adjustable coffin bar spacing
- Spill plate for tipping grid

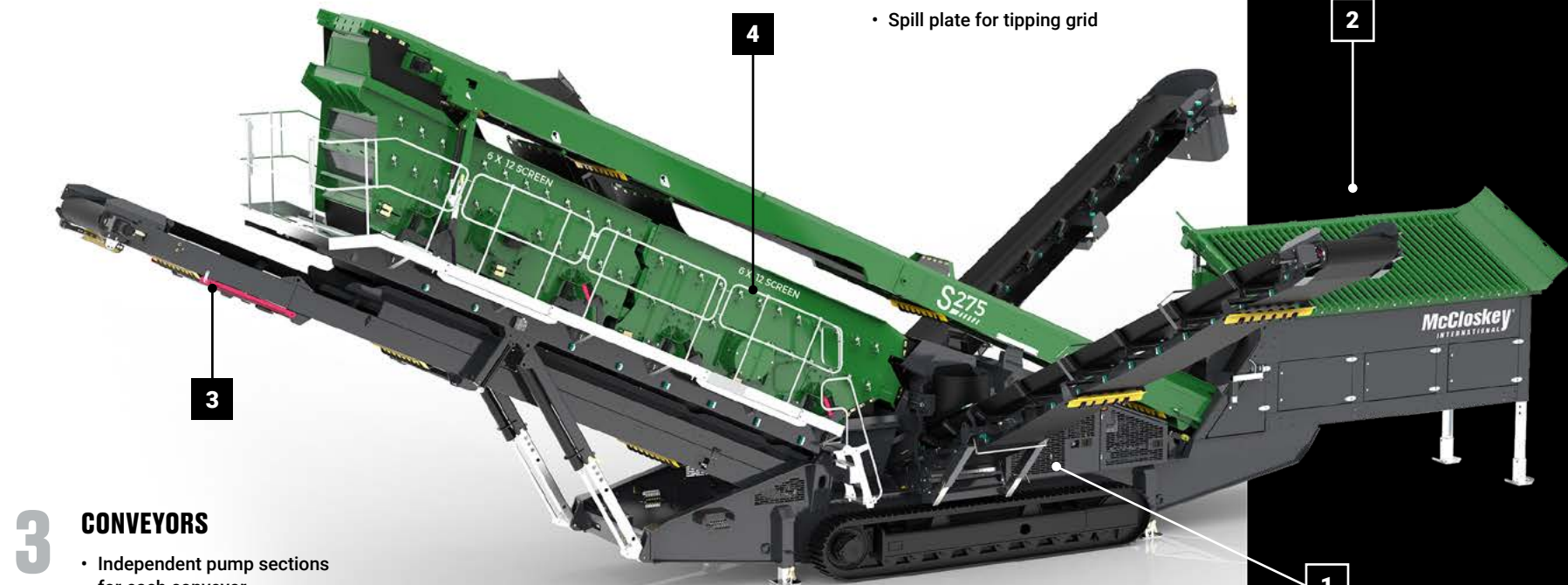

3 CONVEYORS

- Independent pump sections for each conveyor
- Flat belt feed conveyor 48" (1 200 mm)
- Chevron belt on main conveyor 48" (1 200 mm)
- Chevron belt side conveyors 36" (910 mm)
- Flat belt tail conveyor with discharge chute 55" (1 400 mm)

optional

- Dust covers main & tail conveyor
- Tail conveyor discharge chute & spray bar

4 SCREEN BOX

- High-Energy™ screenbox 6' x 24' (1.8 m x 7.3 m)

optional

- 3-Deck configuration with blending option shuttle conveyor

OTHER FEATURES

- Remote machine shut off
- Removeable track control C/W cable
- Tipping grid remote (TGR)

optional

- Single shaft shredder
- Working lights
- Fitted safety beacons

SPECIFICATIONS

ADDITIONAL INFORMATION



SCALPERS R-SERIES

McCloskey
INTERNATIONAL

Give anything to our scalpers : these units work hard to provide clean finished products quickly and efficiently. Equipped with the largest feeders in their class, they can be fed by a loader or excavator. The high energy screenbox makes it the most efficient screener in its category. With thousands sold in Canada, its reputation is well-known.

R70 R105 R155 R230





R70

McCloskey
INTERNATIONAL

	POWER PACK	JCB 444 (84 hp)
	SCREEN BOX	4' x 9' (1.2 m x 2.7 m)
	HOPPER	5.4 yd ³ (4.1 m ³)
	FINES DISCHARGE	11' 8" (3.6 m)
	MIDS DISCHARGE	11' 8" (3.6 m)
	OVERS DISCHARGE	11' 1" (3.4 m)

TRANSPORTATION

	WEIGHT	33 951 lbs (15 400 kg)
	LENGTH	31' 9" (9.9 m)
	WIDTH	8' 2" (2.5 m)
	HEIGHT	10' 6" (3.2 m)

1 POWER PACK

- JCB 444 (84 hp)

optional

- Auxiliary drive circuit (PTO)

2 FEED HOPPER

- 5.4 yd³ (4.1 m³) hopper with 3 ply heavy duty feed belt 48" (1.2 m)
- Hardox® 450 liner
- Extended hopper wing plates 10' (3 m) wide

3 SCREENBOX

- High-Energy™ screenbox 4' x 9' (1.2 m x 2.7 m)



4 CONVEYORS

- Chevron belt on fines discharge 26" (660 mm)
- Chevron belt on mid product 26" (660 mm)
- Chevron belt on tail conveyor 42" (1 000 mm)
- Access hatch

optional

- Dust suppression system
- Screen blanket

OTHER FEATURES

- Removeable track control c/w cable
- Remote machine shut off

optional

- Remote start/stop feeder
- Variable speed & start stop feeder kit
- Working lights
- Safety beacon lights

SPECIFICATIONS







ADDITIONAL INFORMATION







R105

McCloskey
INTERNATIONAL

 POWER PACK	CAT C4.4 (134 hp) / Deutz 3.6 (134 hp)
 SCREEN BOX	4' 6" x 12' (1.4 m x 3.6 m)
 HOPPER	8 yd ³ (6.0 m ³)
 FINES DISCHARGE	11' 10" (3.6 m)
 MIDS DISCHARGE	11' 10" (3.6 m)
 OVERS DISCHARGE	11' 4" (3.5 m)

TRANSPORTATION

 WEIGHT	50 700 lbs (23 000 kg)
 LENGTH	48' 9" (14.7 m)
 WIDTH	8' 4" (2.5 m)
 HEIGHT	10' 6" (3.2 m)

1 POWER PACK

- CAT C4.4 (134 hp)

optional

- Deutz 3.6 (134 hp)
- Auxiliary drive circuit (PTO)

2 FEED HOPPER

- 8 yd³ (6 m³) hopper with 3 ply heavy duty feed belt 48" (1.2 m)
- Hardox® 450 liner
- Hydraulic folding extended hopper wing plates 10' (3 m) wide

Optional

- Steel apron plate feeder

3 SCREENBOX

- High-Energy™ screenbox 4' 6" x 12' (1.4 m x 3.6 m)

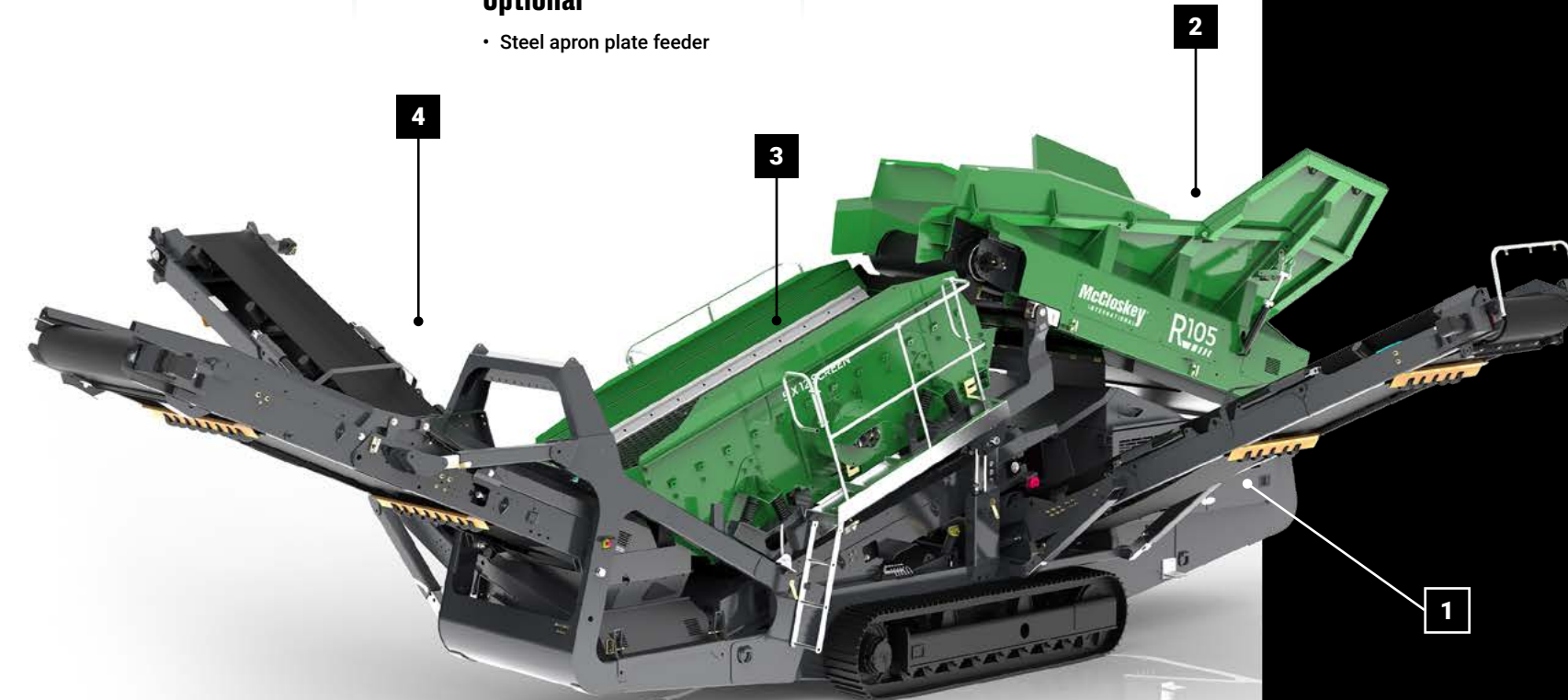

4 CONVEYORS

- Independent pump sections for each conveyor
- Flat belt on fines collection 42" (1 m)
- Access hatch
- Flat belt on fines discharge with spring loaded poly cleaner 32" (810 mm)
- Flat belt on mid product 32" (810 mm)
- Chevron belt on tail 48" (1 200 mm)

optional

- Dust suppression system
- Screen blanket
- Reverse discharge side of fines and/or mid-product conveyor
- Twin drive on the tail conveyor
- Change flat belts to chevron belt (side conveyors)
- Extended tail conveyor
- Overband magnet on tail conveyor on 3 products configuration

OTHER FEATURES

- Removeable track control c/w cable
- Remote machine shut off

optional

- Remote start/stop feeder
- Variable speed & start stop feeder kit
- Working lights
- Safety beacon lights
- Chain curtain (on top deck discharge)

SPECIFICATIONS







ADDITIONAL INFORMATION





R155

McCloskey
INTERNATIONAL

	POWER PACK	CAT C4.4 (131 hp)
	SCREEN BOX	5' x 16' (1.5 m x 4.9 m)
	HOPPER	10 yd ³ (8 m ³)
	FINES DISCHARGE	13' (4.0 m)
	MIDS DISCHARGE	11' 10" (3.6 m)
	OVERS DISCHARGE	13' 3" (3.5 m)

TRANSPORTATION

	WEIGHT	74 800 lbs (34 000 kg)
	LENGTH	50' 2" (15.3 m)
	WIDTH	9' 6" (2.9 m)
	HEIGHT	11' 2" (3.4 m)

1 POWER PACK

- CAT C4.4 (131 hp)

optional

- Dual power electric and diesel hydraulic
- Auxiliary drive circuit (PTO)

2 FEED HOPPER

- 10 yd³ (8 m³) hopper with 3 ply heavy duty feed belt 48" (1.2 m)
- Hardox® 450 liner
- Hydraulic folding extended hopper wing plates 15' (4.6 m) wide

optional

- High volume hopper 14 yd³ (10.7 m³)
- Extended low-load height feeder 15' (4.6 m) wide
- Steel apron plate feeder

3 SCREENBOX

- High-Energy™ screenbox 5' x 16' (1.5 m x 4.9 m)

optional

- Flex-flow style double deck screen box



4 CONVEYORS

- Independent pump sections for each conveyor
- Flat belt on fines collection 48" (1 200 mm)
- Flat belt on fines discharge with spring loaded poly cleaner 36" (900 mm)
- flat belt on mid product 36" (900 mm)
- Chevron belt on tail 55" (1 400 mm)

optional

- Dust suppression system
- Screen blanket
- Reverse discharge side of fines and/or mid-product conveyor
- Twin drive on the tail conveyor
- Change flat belts to chevron belt (side conveyors)
- Extended tail conveyor
- Overband magnet on tail conveyor on 3 products configuration

OTHER FEATURES

- Removeable track control c/w cable
- Remote machine shut off

optional

- Remote start/stop feeder
- Variable speed & start stop feeder kit
- Working lights
- Safety beacon lights
- Chain curtain (on top deck discharge)

SPECIFICATIONS







ADDITIONAL INFORMATION









R230

McCloskey
INTERNATIONAL

	POWER PACK	Volvo D5 (218 hp) / CAT C7 (225 hp)
	SCREEN BOX	6' x 20' (1.8 m x 6.1 m)
	HOPPER	14 yd ³ (10.7 m ³)
	FINES DISCHARGE	13' 6" (4.1 m)
	MIDS DISCHARGE	12' (3.7 m)
	OVERS DISCHARGE	12' 6" (3.8 m)

	TRANSPORTATION	
	WEIGHT	83 600 lbs (38 000 kg)
	LENGTH	55' 8" (17 m)
	WIDTH	9' 10" (3 m)
	HEIGHT	11' 5" (3.5 m)

1 POWER PACK

- Volvo D5 (218 hp)
- optional**
- CAT C7 (225 hp)
- Auxiliary drive circuit (PTO)
- Dual power electric and diesel hydraulic

2 FEED HOPPER

- 14 yd³ (10.7 m³) hopper with 3 ply heavy duty feed belt 60" (1.5 m)
- Hardox® 450 liner
- Hydraulic folding extended hopper wing plates 17' (5.2 m) wide
- optional**
- High volume hopper 18 yd³ (13.8 m³)
- Extended low-load height feeder 17' (5.2 m) wide
- Steel apron plate feeder

3 SCREENBOX

- High-Energy™ screenbox 6' x 20' (1.8 m x 6.1 m)
- optional**
- Flex-flow style double deck screen box

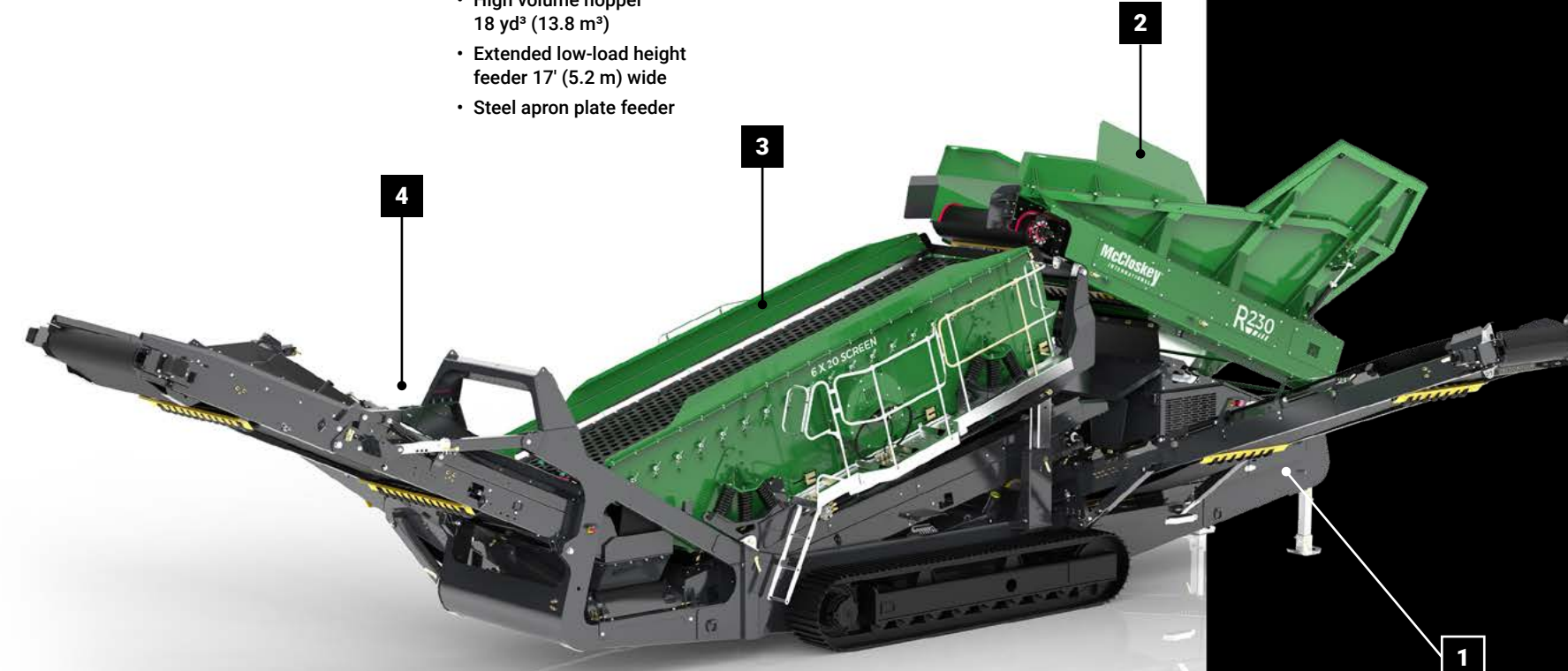

4 CONVEYORS

- Independent pump sections for each conveyor
- Flat belt on fines collection 55" (1 400 mm)
- Flat belt on fines discharge with spring loaded poly cleaner 42" (1 050 mm)
- Flat belt on mid product 36" (900 mm)
- Chevron belt on tail 64" (1 600 mm)
- optional**
- Dust suppression system
- Screen blanket
- Reverse discharge side of fines and/or mid-product conveyor
- Twin drive on the tail conveyor
- Change flat belts to chevron belt (side conveyors)
- Extended tail conveyor
- Overband magnet on tail conveyor on 3 products configuration

OTHER FEATURES

- Removeable track control c/w cable
- Remote machine shut off
- optional**
- Remote start/stop feeder
- Variable speed & start stop feeder kit
- Working lights
- Safety beacon lights
- Chain curtain (on top deck discharge)

SPECIFICATIONS

ADDITIONAL INFORMATION



CONVEYORS

It is no secret that conveyors save money. Anyone who has used a conveyor for stock piling and material transfer does not go back to previous methods. McCloskey offers a full range of stockpiling and transfer solutions.

ST80 T/V/LA ST100 T/V/LA SF80

McCloskey
INTERNATIONAL





ST80 T/V/L/A

The world's most successful portable stacker model is available with a large variety of options to accommodate all operations and transport requirements. The ST80 is known for its incredible value and reputation of reliability.

McCloskey
INTERNATIONAL

1 POWER PACK

- Kubota V2208 (49 hp)

optional

- CAT C2.8 (74 hp)
- Electric tefc 25 hp heavy duty high efficiency 1750 rpm
- Electrical panel
- Hydraulics upgraded to 750 TPH (includes CAT C2.8 - 74 hp)

2 HOPPER

- Standard hopper 6' (1.8 m) width
- Hopper extensions 9' (2.7 m) width

optional

- Direct feed v-bin (c/w landing gear & CAT C2.8 - 74 hp)
- Impact idlers under hopper
- Hopper wear plates

3 BELT

- 3 ply - 3/16 x 1/16 (57 mm x 19 mm)

optional

- 3 ply chevron

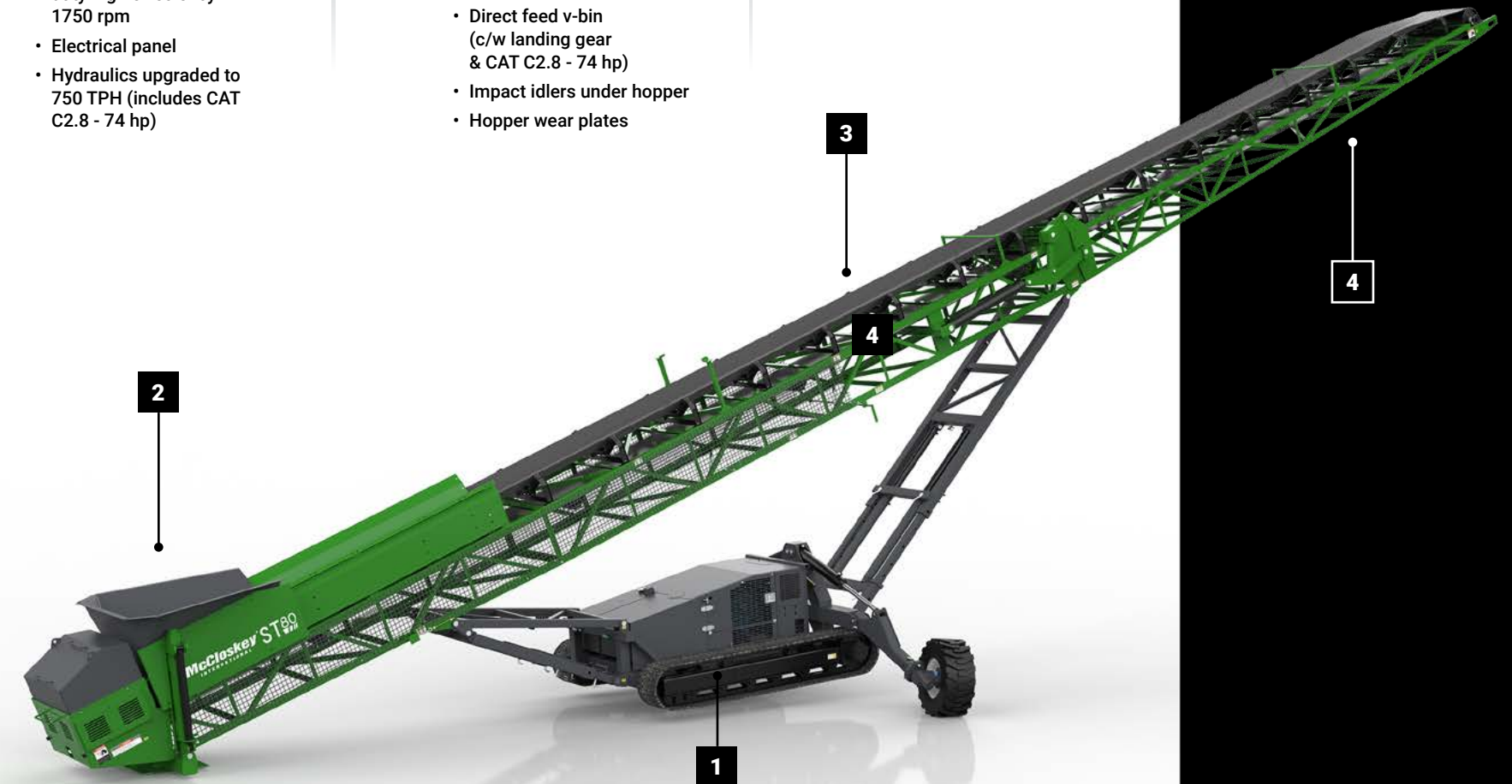

4 FEATURES

- Remote greaselines
- Counter weight design for higher stockpiling (ST80 = 100' conventional)

optional

- Reduce conveyor length to 65'
- Overband magnet on conveyor

OTHER FEATURES (OPTIONAL)

- Hydraulic axle jacks
- Hydraulic axle extensions
- Hydraulic landing gear
- Hydraulic wheel drive
- Spray bar
- Auxillary guarding
- Paddle wheel
- Upgraded belt cleaner/scrapper

SPECIFICATIONS

ADDITIONAL INFORMATION





ST100 T/V/L/A

McCloskey
INTERNATIONAL

The next level in portable stockpiling capacity. The ST100 series has all same available options as the ST80 but with 40 % more stockpiling capacity.

1 POWER PACK

- CAT C2.8 (74 hp)

optional

- Electric tefc 25 hp heavy duty high efficiency 1750 rpm
- Electrical panel
- Hydraulics upgraded to 750 TPH (includes CAT C2.8 - 74 hp)

2 HOPPER

- Standard hopper 6' (1.8 m) width
- Hopper extensions 9' (2.7 m) width

optional

- Direct feed v-bin (c/w landing gear & CAT C2.8 - 74 hp)
- Impact idlers under hopper
- Hopper wear plates

3 BELT

- 3 ply - 3/16 x 1/16 (57 mm x 19 mm)

optional

- 3 ply chevron



4 CONVEYORS

- Remote greaselines
- Counter weight design for higher stockpiling (ST80 = 125' conventional)

optional

- Overband magnet on conveyor

OTHER FEATURES (OPTIONAL)

- Hydraulic axle jacks
- Hydraulic axle extensions
- Hydraulic landing gear
- Hydraulic wheel drive
- Spray bar
- Auxillary guarding
- Paddle wheel
- Upgraded belt cleaner/scrapper

SPECIFICATIONS



ADDITIONAL INFORMATION









SF80

McCloskey
INTERNATIONAL

 POWER PACK	CAT 3.6 100 KW (127 hp)
 HOPPER	17 yd ³ (13 m ³)
 DISCHARGE	31' 5" (9.6 m)

TRANSPORTATION	
 WEIGHT	54 000 lbs (24 500 kg)
 LENGTH	38' 8" (19.4 m)
 WIDTH	10' 6" (3.2 m)
 HEIGHT	11' 1" (3.4 m)

1 POWER PACK

- CAT 3.6 100KW (136 hp)
- Dual hydraulic main drive system
- Fuel efficient hydraulic system

2 HOPPER

- Standard hopper 6' (1.8 m) width
- Hopper extensions 9' (2.7 m) width

optional

- Mulch hopper
- Aggregate hopper

3 BELT

- 3 ply - 3/16 x 1/16 (57 mm x 19 mm)

optional

- 3 ply chevron

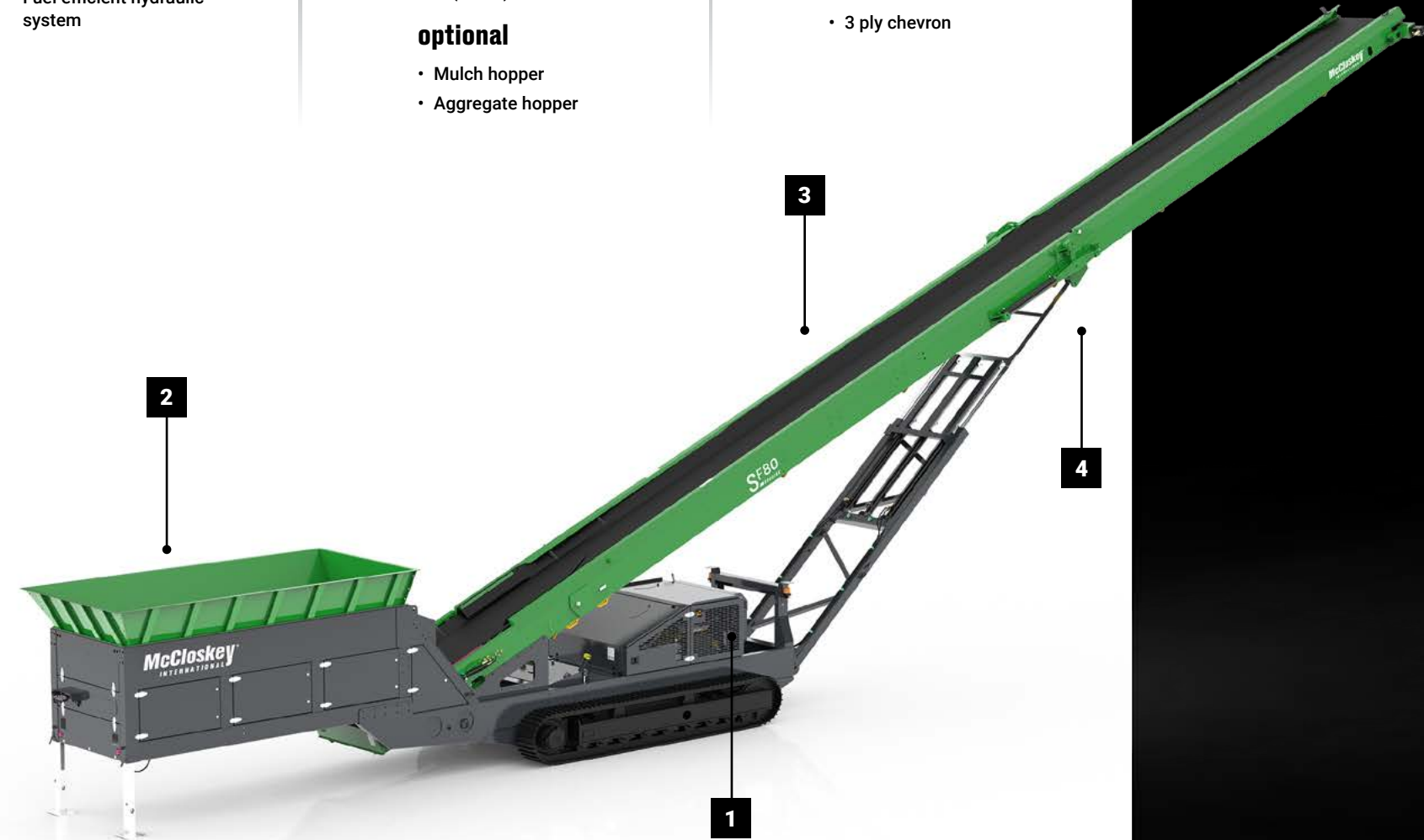

4 CONVEYORS

- Remote greaselines
- Hydraulic folding heading section for transport minimizing setup time
- Hydraulically adjustable discharge height up to 31' 5" (9.6 m)
- 48" (1.2 m) hot-spliced main conveyor
- 48" (1.2 m) hot-spliced fee

OTHER FEATURES (OPTIONAL)

- Hydraulic tipping grid
- Livehead
- Hardox liners
- Paddle wheel
- Upgraded belt cleaner/scrapper

SPECIFICATIONS

ADDITIONAL INFORMATION





REDUCE HANDLING









4065T

 POWER PACK	CAT C2.2 74 hp (55 Kw)
 BELT WIDTH	3 ply 40" (1 m)
 STOCKPILE HEIGHT	26' (7.6 m)



TRANSPORTATION

 WEIGHT	25 240 lbs (11 450 kg)
 LENGTH	39' 9" (12.2 m)
 WIDTH	7' 6" (2.3 m)
 HEIGHT	8' 3" (2.5 m)

ADDITIONAL INFORMATION



OPTIONS

- FEED BOOT RUBBER LINERS
- HEAD SCRAPER UPGRADE
- ANTI-ROLL BACKS
- REAR HYDRAULIC FOLDING JACK LEGS
- EXTENDED FEED BOOT WITH MATERIAL SHELF
- HEAVY DUTY 4 PLY BELT

SMARTER WASHING SOLUTIONS



MWS 
EQUIPMENT

SCREW



ADDITIONAL
INFORMATION



SPECIFICATIONS

1 MCCLOSKEY GEAR REDUCER <ul style="list-style-type: none"> • Heavy-duty design with heat-treated helical gears • Triple reduction gearing allows 100 % to 16 % speed changes • 100 % of the shaft's thrust load carried by the outputshaft(s) • Oil bath lubrication for maintenance-free operation • Drive guards standard equipment 	2 HULLZ <ul style="list-style-type: none"> • Fabricated with thick gauge steel • Close-clearance curved plate runs entire length of shaft • Extra-wide side flares for maximum product retention • Adjustable weirs for out of level conditions • Spherical-roller rear grease bearing(s) • High-efficiency electric motor(s) 	3 FEED BOX <ul style="list-style-type: none"> • Internal and external baffles to deaden feed velocities • Provides uniform slurry mixture for maximum product retention
4 WEAR SHOES <ul style="list-style-type: none"> • Wear shoes cover the full face of spiral • Optional urethane wear shoes available 	5 SCREW SHAFT <ul style="list-style-type: none"> • Helical spiral segments with continuous submerged arc weld • Extra-thick, one piece shaft tubing 	OTHER EQUIPEMENT <ul style="list-style-type: none"> • Washer supports • Overflow weir • Drain plugs • Discharge chute

MODELS	3625S	4432T	4432S	4432T
⚡ MOTOR POWER RECOMMENDED	15 hp	15 hp x 2	25 hp	25 hp x 2
Ⓒ MAX SCREW SPEED	20 rpm	20 rpm	17 rpm	17 rpm
↔ MAX FEED (MTPH)	100 (90)	200 (130)	100 (90)	200 (130)
↔ LENGTH	28' (8.6 m)	28' (8.5 m)	35' (10.5 m)	35' (10.5 m)
↗ WIDTH	8' (2.6 m)	12' (3.6 m)	12' (3.6 m)	16' (4.9 m)
↑ HEIGHT	13' (3.9 m)	13' (3.9 m)	15' (4.8 m)	16' (4.9 m)

CSP

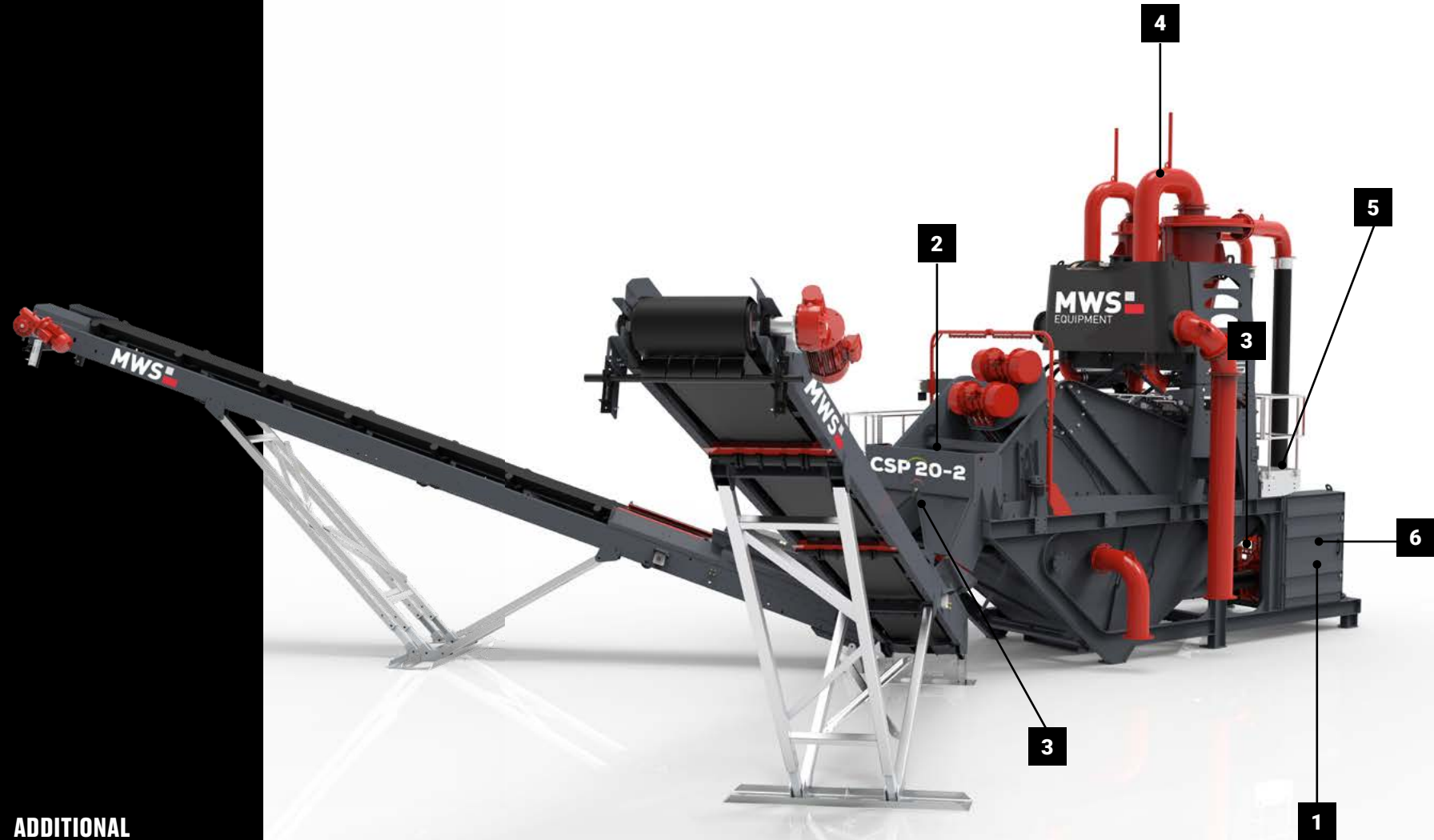

ADDITIONAL
INFORMATION



MWS
EQUIPMENT

SPECIFICATIONS

<p>1 MAIN TANK</p> <ul style="list-style-type: none"> • Access hatch • Self regulating • Lh/Rh Drain valve • Anti turbulence cell • Large access hatch for maintenance 	<p>2 DEWATERING SCREEN</p> <ul style="list-style-type: none"> • Dewatered sand is discharged readyfor market • Twin vibrating motors with adjustable throw • 200 mm high Polyurethane side liners • Fitted with Polyurethane modules 	<p>3 CHUTE</p> <ul style="list-style-type: none"> • Wear lined discharge chute • Adjustable chute for material blending
<p>4 HYDROCYCLONES</p> <ul style="list-style-type: none"> • Hydrocyclones produce highly accurate separation of silts and clays from the final washed sand product • Pump to hydrocyclone delivery system fully rubber lined ensuring maximum wear resistance 	<p>5 WALKWAYS</p> <ul style="list-style-type: none"> • Galvanised walkways & access steps • 30 inch (760 mm) wide walkways • Side and back of screen walkways for maintenance 	<p>6 CONTROL PANEL(OPTIONAL)</p> <ul style="list-style-type: none"> • IP65 Weather resistant enclosure • LED/Strip lighting

MODELS	CSP6		CSP12		CSP20		CSP30	
	One Sand	Two Sand	One Sand	Two Sand	One Sand	Two Sand	One Sand	Two Sand
⚡ MOTOR - HP (KW)	32 (24)	37.5 (28)	59 (44)	68 (51)	82 (62)	102 (77)	127 (95)	141 (105)
⚙️ PUMP - HP (KW)	25 (18.5)	20 (10) 10 (7.5)	40 (30)	29.5 (22) 20 (15)	60 (45)	40 (30) 40 (30)	100 (75)	74 (55) 40 (30)
🏠 DEWATERING SYSTEM - HP (KW)	2/4 (2/3)	2/4 (2/3)	2/6 (2/4.5)	2/6 (2/4.5)	2/11 (2/8.5)	2/11 (2/8.5)	2/13.5(2/10)	2/13.5(2/10)
💧 WATER REQUIREMENT - G/M (M ³ /HR)	660 (150)	660 (150)	1300 (300)	1300 (300)	2200 (500)	2200 (500)	3300 (750)	3300 (750)
↔️ PRODUCTION - TPH	66 (60)		132 (120)		220 (200)		300 (272)	

SANDSTORM

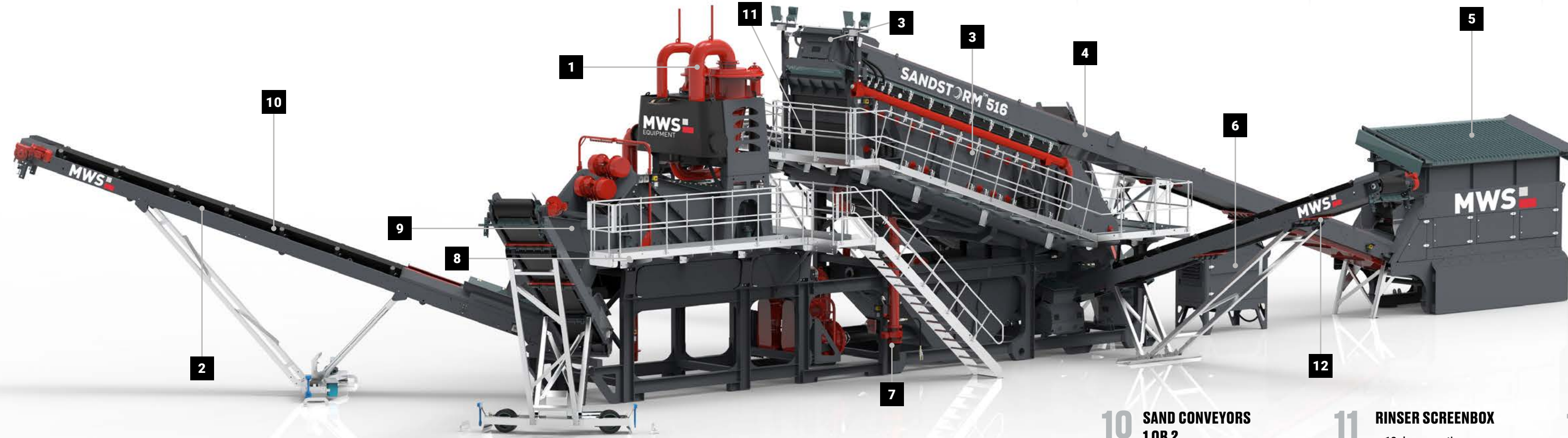

1 HYDROCYCLONES

- Hydrocyclones produce highly accurate separation of silts and clays from the final washed sand product
- Pump to hydrocyclone delivery system fully rubber lined ensuring maximum wear resistance

2 WASHBOX

- Fully enclosed, sealed and rubber lined wash box
- Easily replaceable rubber lining
- Water saturation of material
- Targeting of material at rear of screenbox maximising screening area

3 CHUTE

- Blending chute
- Chute rolls back for maintenance

4 MAIN CONVEYOR

- 41" (1 050 mm) wide belt
- High quality polyurethane scraper
- Galvanised undercarriage
- Overband magnet option

5 FEED/HOPPER

- Adjustable feeder and hopper door for consistent material feed
- Large capacity 15' hopper 16 yd³ (12 m³)
- Radio controlled Tipping grid
- Grid spacing 4"
- Vibrating grid option
- Variable speed belt feeder

2

10

9

8

1

11

7

9 DEWATERING SCREEN

- Dual and single sand options up to 200 TPH
- Dewatered sand is discharged ready for market

3

3

4

6

12

10 SAND CONVEYORS 1 OR 2

- 37' (11.3 m) sand conveyors
- Automated Radial
- 20 degree incline
- Stockpile capacity 575 yd³ (440 m³)
- High quality polyurethane scraper
- Galvanised undercarriage
- 100' (30.5 m) conveyor option

11 RINSER SCREENBOX

- 18 degree optimum working angle
- Rosta tensioned belt drive unit for increased belt life, efficiency and ease of maintenance
- Isolated spraybars
- Integrated fully sealed subframe and catchbox

12 AGGREGATE CONVEYORS 2 OR 3

- 37' (11.3 m) aggregate conveyors
- Positioned to the left or right
- 18 degree incline
- Stockpile capacity 25 yd³ (95 m³)
- High quality polyurethane scraper
- Galvanised undercarriage

6 POWERPACK

- Electric hydraulic powerpack for maximum control of feeder functions

7 MAIN TANK

- Large inspection door(s) on tank

8 WALKWAYS

- Galvanised walkways
- 30" (760 mm) wide walkways

SANDSTORM



MWS
EQUIPMENT

ADDITIONAL
INFORMATION



SPECIFICATIONS

SANDSTORM 516

	2 Deck 1 Sand	2 Deck 2 Sand	3 Deck 1 Sand	3 Deck 2 Sand
Feed rate (Max. STPH)	330	330	330	330
Sand production (Max. STPH)	132	132	132	132
No of products / Sand	2/1 (3)	2/2 (4)	3/1 (4)	3/2 (5)
Water requirement (USgpm)	1100-1320	1100-1320	1100-1320	1100-1320
Power requirements (hp)	172	185	172	185
Screen box dimensions	16' x 5'	16' x 5'	16' x 5'	16' x 5'
DW screen dimensions	12' x 5'	12' x 5'	12' x 5'	12' x 5'
Overall dimensions (L x W x H)	131' x 59' x 25'	124' x 59' x 25'	131' x 65' x 25'	124' x 65' x 25'

SANDSTORM 620

	2 Deck 1 Sand	2 Deck 2 Sand	3 Deck 1 Sand	3 Deck 2 Sand
Feed rate (Max. STPH)	551	551	551	551
Sand production (Max. STPH)	220	220	220	220
No of products / Sand	2/1 (3)	2/2 (4)	3/1 (4)	3/2 (5)
Water requirement (USgpm)	1980-2200	1980-2200	1980-2200	1980-2200
Power requirements	212	236	212	236
Screen box dimensions	20' x 6'	20' x 6'	20' x 6'	20' x 6'
DW screen dimensions	14' x 6'	14' x 6'	14' x 6'	14' x 6'
Overall dimensions (L x W x H)	131' x 59' x 25'	124' x 59' x 25'	131' x 65' x 25'	124' x 65' x 25'

AGGSTORM

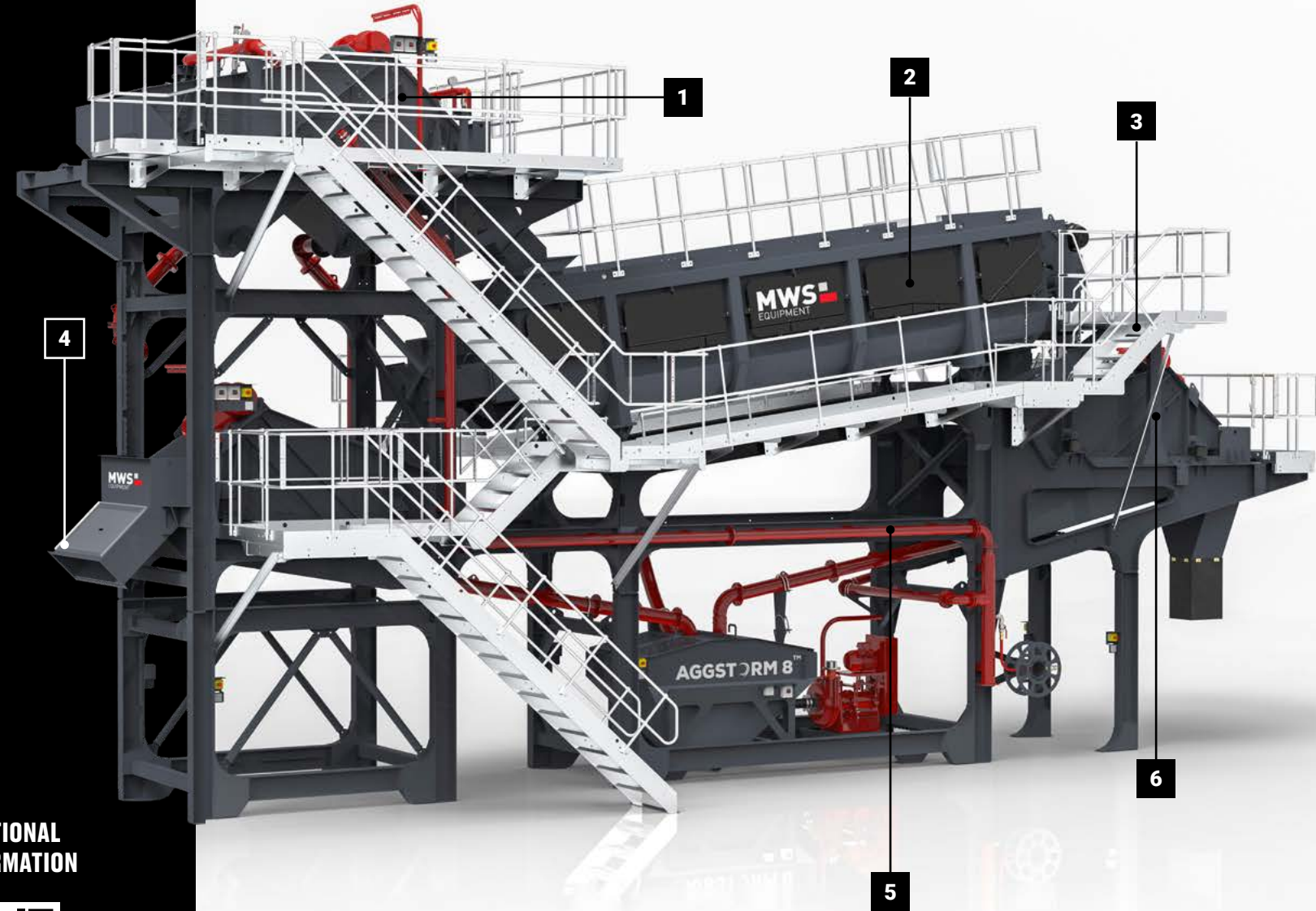

MWS
EQUIPMENT

ADDITIONAL
INFORMATION



SPECIFICATIONS

<p>1 LOGWASHER PRESCREEN</p> <ul style="list-style-type: none"> • Single and double deck pre screen option to remove sand prior to logwasher • Isolated spraybars • Rubber lined catchbox and chute for wear and noise reduction. 	<p>2 LOG WASHER</p> <ul style="list-style-type: none"> • Twin shaft log washer • Multiple paddle configurations • Access doors to allow ease of maintenance to logwasher hull 	<p>3 WALKWAYS</p> <ul style="list-style-type: none"> • Full access to all areas of machine • Galvanised walkways as standard • 2.5' (762 mm) wide walkways
<p>4 TRASH SCREEN</p> <ul style="list-style-type: none"> • Linear vibrating screen for the removal of lights and trash contaminants • Rubber lined catchbox and chutes for wear and noise reduction 	<p>5 PIPEWORK</p> <ul style="list-style-type: none"> • Pre-plumbed at factory • Rubber lined pipework at wear points 	<p>6 AGGREGATE RINSING SCREEN</p> <ul style="list-style-type: none"> • Multiple screen options producing up to 3 aggregates • Isolated spraybars • Rubber lined catchbox and chute for wear and noise reduction.

MODELS	8	15	XL
⚡ POWER REQUIREMENT	68 hp (51 kw)	79 hp (59 kw)	100 hp (75 kw)
↔ CAPACITY	66-86 STPH (60-80 mTPH)	88-165 STPH (80-150 mTPH)	165-220 STPH (150-200 mTPH)
💧 WATER REQUIREMENT	350 USgpm (80 m ³ /hr)	440 USgpm (100 m ³ /hr)	440 USgpm (100 m ³ /hr)
↔ LENGTH	26' (8 m)	32' (10 m)	32' (10 m)
↗ WIDTH	17' (5.1 m)	17' (5.1 m)	17' (5.1 m)
↑ HEIGHT	24' (7.2 m)	26' (8 m)	26' (8 m)

ULTRA FINES RECOVERY



MWS
EQUIPMENT

ADDITIONAL
INFORMATION



SPECIFICATIONS

1 High efficiency recovery of overflow from sand plant	2 Designed to reduce the volume of material going to a settling pond or filter press	3 Small diameter cyclones design to maximise recovery of material 38 μ (#400) and above
4 Flexibility of design and throughput to match customer demand	5 Quick installation and setup	6 Various control system options available

MODELS	UFR 6	UFR 12	UFR 20	UFR 30
MOTOR	50 hp (37 kw)	60 hp (45 kw)	100 hp (75 kw)	150 hp (110 kw)
CYCLONES	2	3	5	8
PUMP	6/5 (150/125)	8/6 (200/150)	10/8 (250/200)	10/8 (250/200)
FLOW RATE	760 USGPM (170 m ³ /hr)	1270 USGPM (290 m ³ /hr)	2540 USGPM (580 m ³ /hr)	3810 USGPM (865 m ³ /hr)
SCREEN	8' x 4' (2.4 x 12 m)	8' x 4' (2.4 x 12 m)	8' x 4' (2.4 x 12 m)	8' x 4' (2.4 x 12 m)

LEGENDARY CRUSHING SYSTEMS



LIPPMANN



PORTABLE EQUIPMENT

In any crushing scenario, attention to detail is of utmost importance to maximize crushing efficiency and profitability. AULT sales representatives are dedicated to analyzing a customer's crushing application and choosing the most cost efficient equipment to get the job done. This concept has been fortified with customizable portable plants, offering numerous options for plant design and ensuring customer satisfaction.

LIPPMANN

**ADDITIONAL
INFORMATION**





LJ3062 / LWM6042

LIPPMANN

Lippmann custom engineers material recycling systems mounted on heavy duty chassis which incorporate robust feeding, crushing, screening and conveying equipment designed for high productivity, easy transit, quick set-up and tear down, and reduced wear costs. In recycle applications, plants feature electro-magnets, specialized belting, custom wear alloys and other options to suit your specific requirements.

1 HOPPER

- 62" x 20' (1.5 m x 6 m) heavy duty feeder
- 72" length of grizzly bars

2 PANEL

- Removeable electric panel

3 MÂCHOIRE

- 30" x 62" (0.75 m x 1.5 m)
- Large & aggressive 1.5" stroke
- Hydraulic toggle and adjust

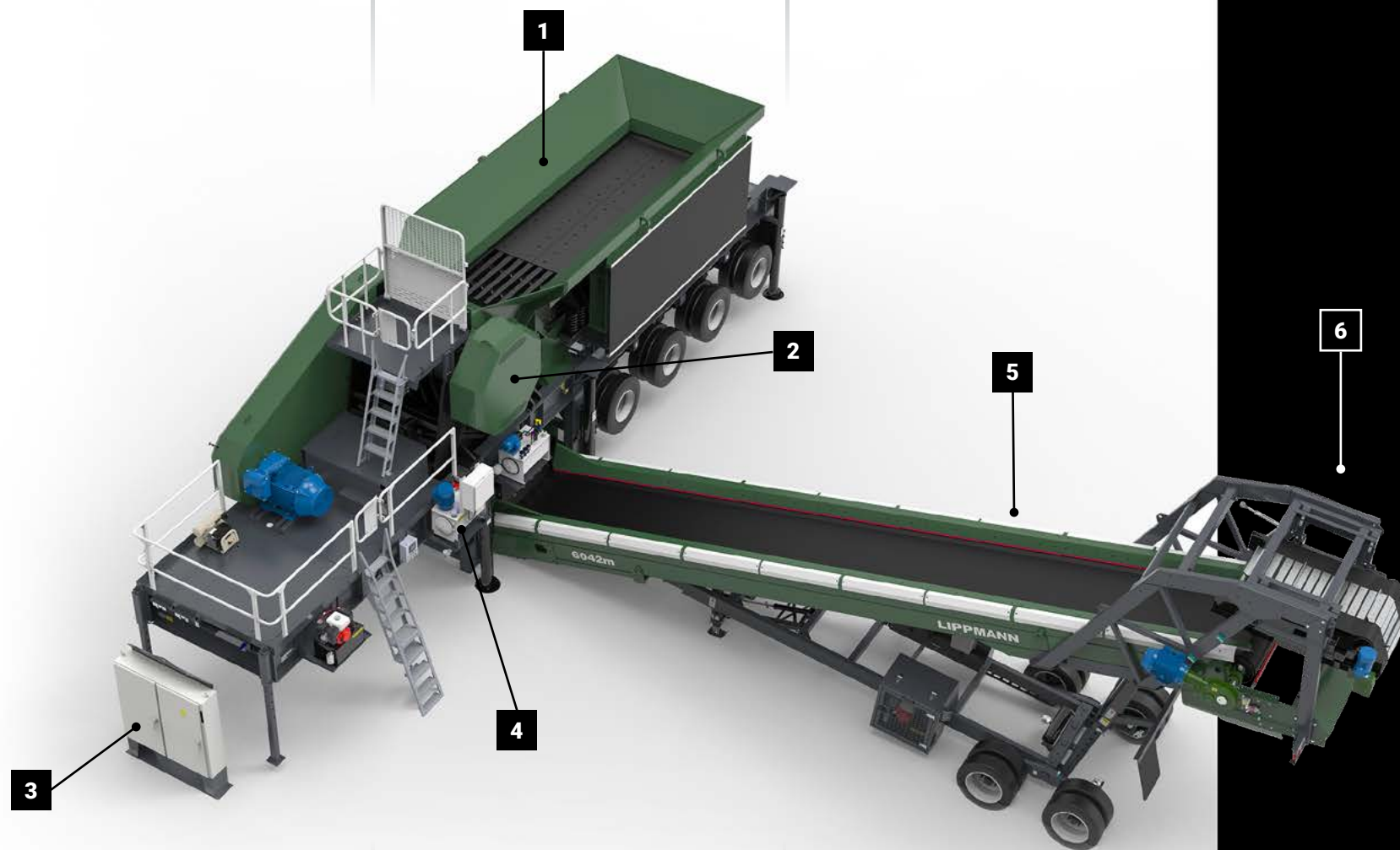

4 UNDERPAN

- Twin motors underpan feeder

5 CONVEYOR

- 60" x 42' (1.5 m x 13 m) long conveyor with 0 degree troughing for maximum steel exposure

6 MAGNET

- Powerful DINGS electromagnet with steel-plated belt

SPECIFICATIONS

ADDITIONAL INFORMATION





4800R

The new 4800R is an all-in-one recycle plant. Able to by-pass fines, crush and screen 2 fractions in closed or open-circuit, the 4800 provides an efficient recycle solution in one move. Using a 16' Lippmann feeder, a 4248 Lippmann Impactor, and McCloskey 6' x 14' high-energy screen box, it creates a highly productive and efficient mobile solution.

LIPPMANN

ADDITIONAL
INFORMATION



AUXILIARY POWER PLUGS FOR STACKERS

6' X 14' DOUBLE DECK SCREEN

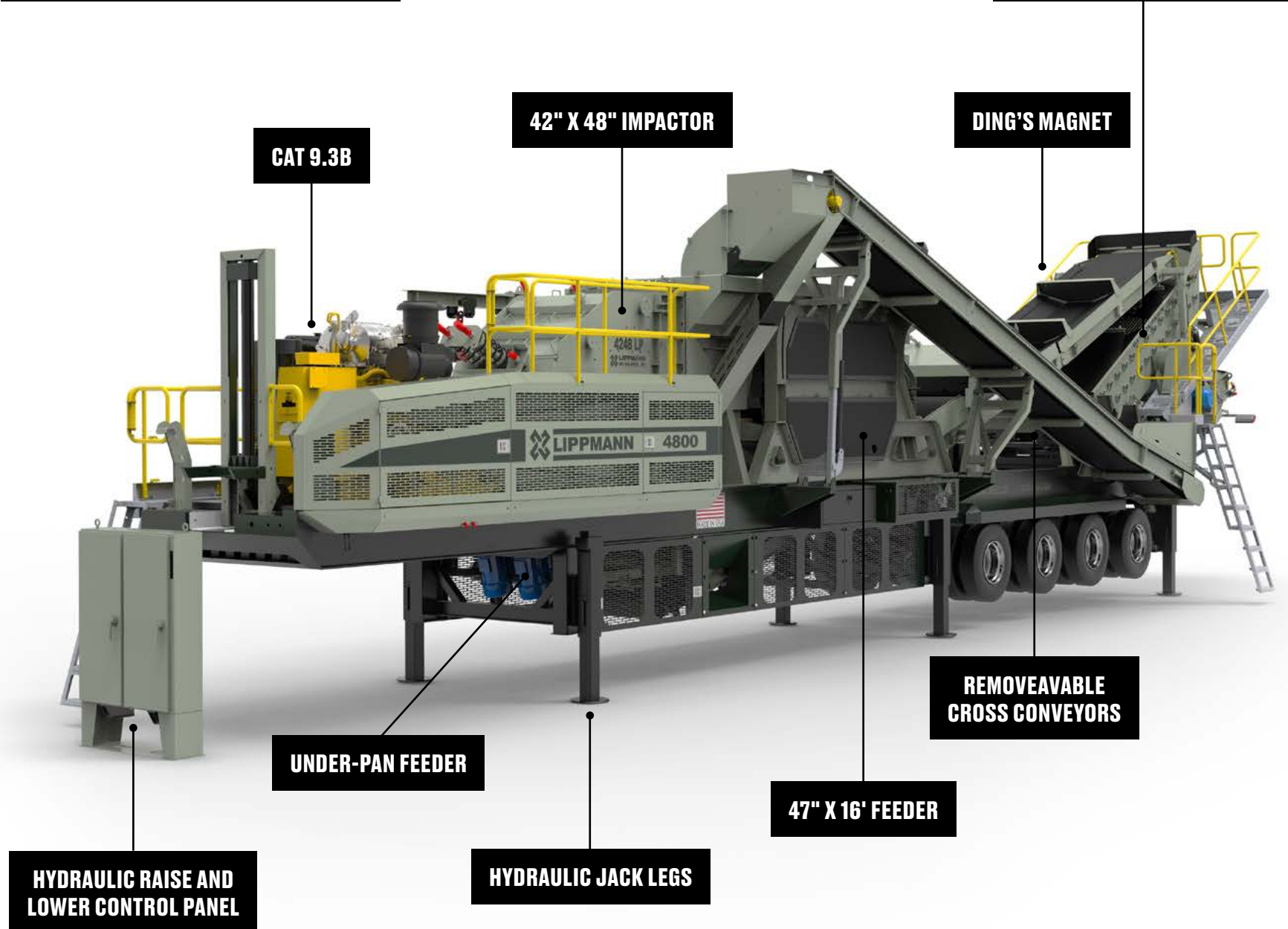

CAT 9.3B

42" X 48" IMPACTOR

DING'S MAGNET

HYDRAULIC RAISE AND
LOWER CONTROL PANEL

HYDRAULIC JACK LEGS

47" X 16' FEEDER

REMOVEABLE
CROSS CONVEYORS

4800R

POWER	Engine	Diesel Electric CAT9.3B (416 hp)
FEATURES	Pan feeder	47" x 16' (1.2 m x 4.8 m)
	Bypass Grizzly	48" x 72" (1.2 m x 1.8 m)
	Double deck screen	6' x 14' (1.8 m x 4.3 m)
TRANSPORT DIMENSIONS	Height	13' 11" (4.2 m)
	Width	11' 11" (3.6 m)
	Length	63' 8" (19.4 m)
	Kingpin weight	40 980 lbs (18 588 kg)
	Axle weight	72 000 lbs (32 658 kg)

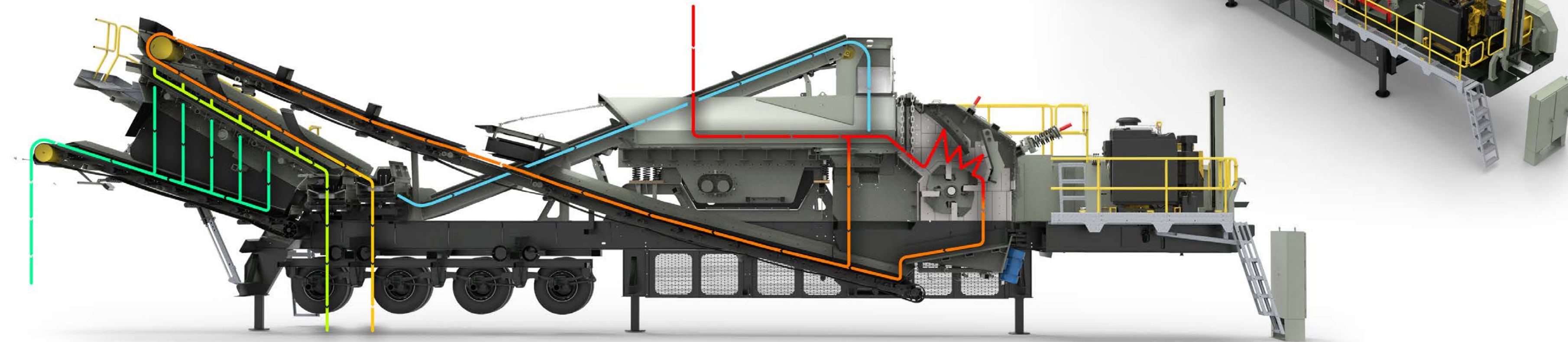





■ FEED MATERIAL
 ■ CRUSHED
 ■ NET STONE 2
 ■ NET STONE 1
 ■ FINISHED O-X PRODUCT
 ■ RETURN

LIPPMANN







LJ3447

LIPPMANN

 FINAL RUNNING LOAD	289.4 kVA (259.7 kW)
 JAW	34" x 47" (870 mm x 1 200 mm)
 HOPPER	31.4 yd ³ (24 m ³)
 CONVEYOR	54" (1 400 mm)
 DISCHARGE	18' (5.5 m)

TRANSPORTATION

 WEIGHT-1	5th Wheel 53 000 lbs (24 000 kg) Quad Axle 74 000 lbs (33 550 kg)
 WEIGHT-2	Hopper cartridge 67 500 lbs (30 600 kg)
 LENGTH	60' 9" (18.5 m)
 WIDTH	11' 11" (3.4 m)
 HEIGHT	14' (4.3 m)

1 HOPPER

- Large capacity
- 20' (6 m) tip to tip for rear feeding
- Rubber lined
- Hydraulically folding and lifting off

2 FEEDER

- 51" x 20' (15.5 m x 6 m)
- Bolted 1" (25 mm) AR base
- Bolted 5/8" (15 mm) walls
- 50 hp drive

3 JAW

- 34" x 47" (800 mm x 1 200 mm) mine duty jaw crusher
- Hydraulic wedge adjustment
- 200 hp integrated drive

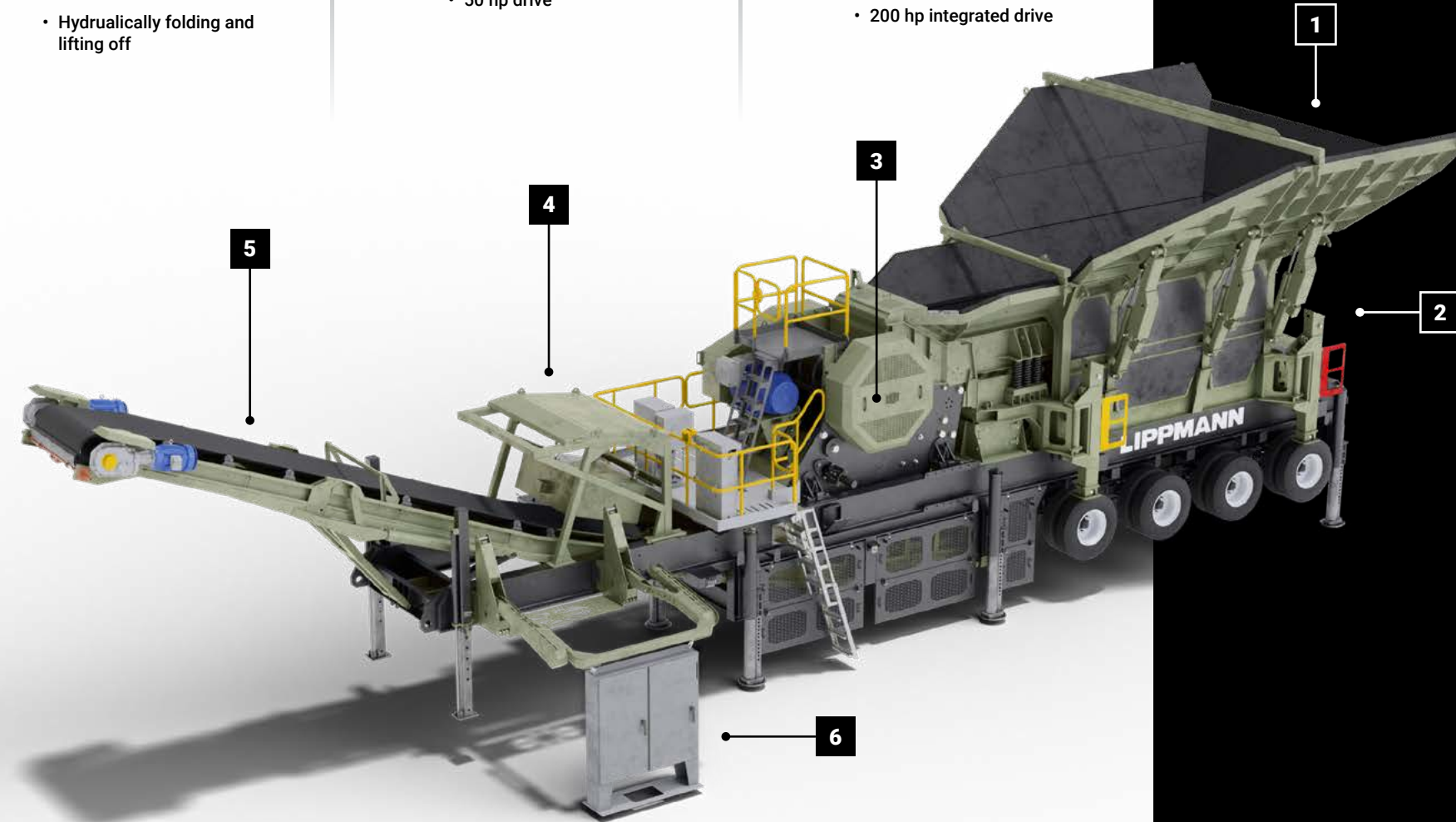

4 MAGNET

- Permanent electromagnet

5 CONVEYOR

- 54" (1.4 m) wide with 18' (5.5 m) stock pile height
- Rock shelf receiver with Brunone impact bed
- Hydraulic top fold
- Twin 15 hp 90 degree drives

6 CONTROLS

- Hydraulic lowering control panel

SPECIFICATIONS





ADDITIONAL INFORMATION











LJ3951

LIPPMANN

-  **FINAL RUNNING LOAD** 325 kVA (281 kW)
-  **JAW** 39" x 51" (1 000 mm x 1 300 mm)
-  **HOPPER** 36.6 yd³ (28 m³)
-  **CONVEYOR** 60" (1 525 m)
-  **DISCHARGE** 18' (5.5 m)

TRANSPORTATION

-  **CHASSIS** Quad Axle 49 530 lbs (20 830 kg)
5th Wheel 29 320 lbs (13 300 kg)
-  **JAW** 110 000 lbs (50 000 kg)
-  **HOPPER** 98 250 lbs (44 500 kg)
-  **LENGTH** 60' 9" (18.5 m)
-  **WIDTH** 11' 11" (3.4 m)
-  **HEIGHT** 14' (4.3 m)

1 HOPPER

- Large Capacity
- 20' (6 m) tip to tip for rear feeding
- Rubber lined
- Hydraulically folding and lift off

2 FEEDER

- 51"x 24' (1.2 m x 6 m)
- Bolted 1" (25 mm) AR base
- Bolted 5/8" (15 mm) walls
- 60 hp drive

3 JAW

- 39"x 51" (1 000 mm x 1 300 mm) mine duty jaw crusher
- Hydraulic wedge adjustment
- 250 hp integrated drive

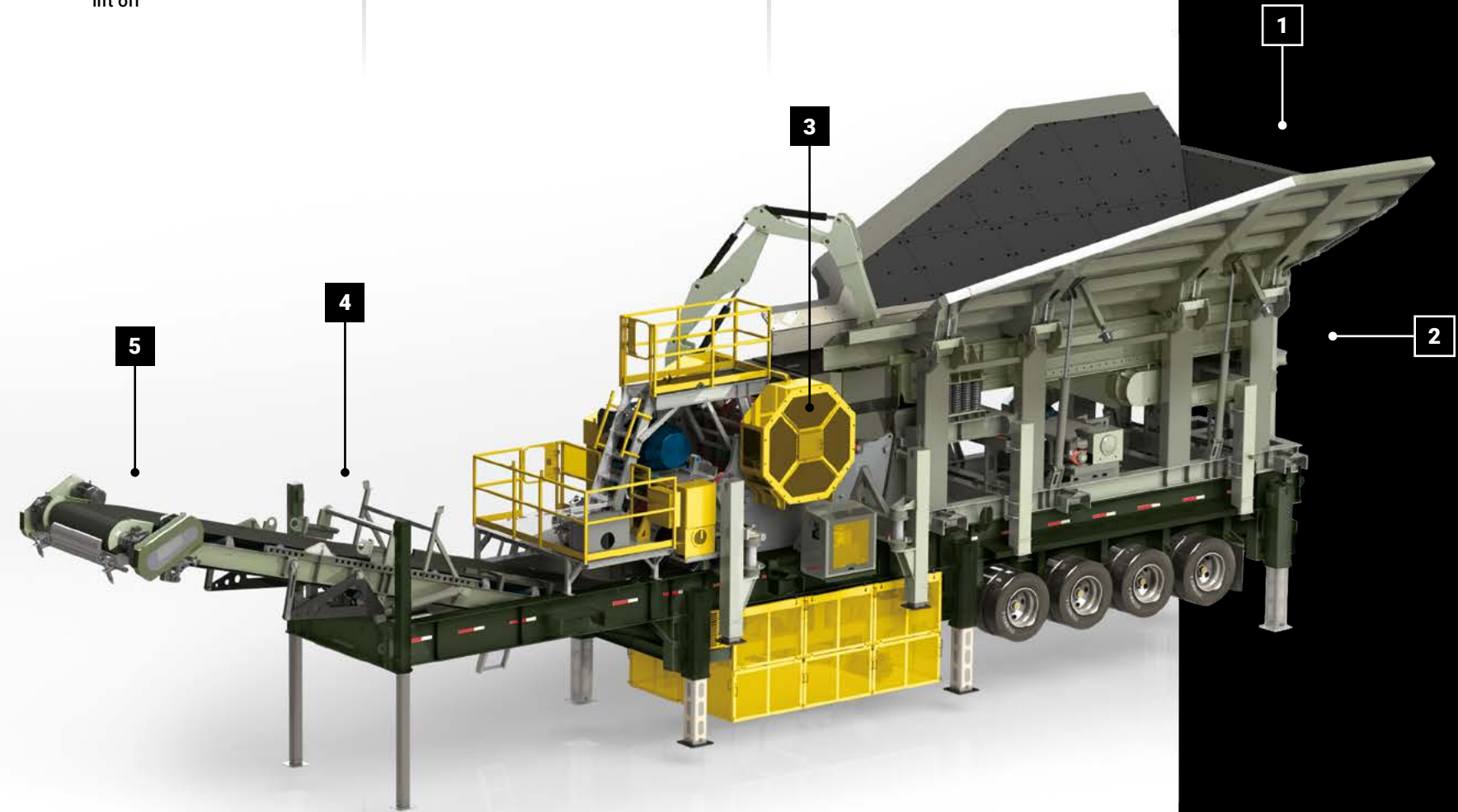

4 MAGNET

- Permanent electromagnet

5 CONVEYOR

- 60" (1.5 m) wide with 18' (5.5 m) stock pile height
- Rock shelf receiver with Brunone impact bed
- Hydraulic top fold
- Twin 20 hp 90 degree drives

SPECIFICATIONS

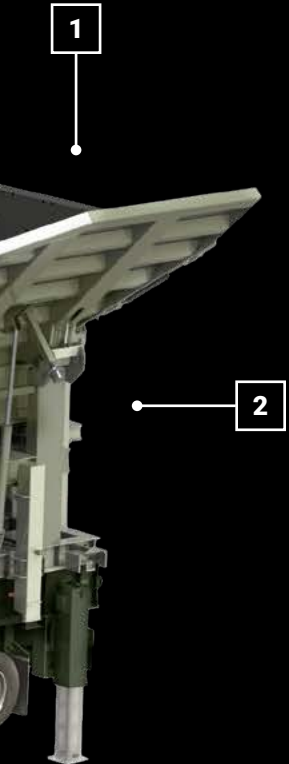

ADDITIONAL INFORMATION





INCLINE SCREENS

An offering of complete inclined screen plants designed for and perfected by operators. Using the Haver & Boeker F-Class screen box, we offer 6x20, 7x20, 8x20, and 8x24 configurations. The plants all feature wide, high-capacity conveyors with excellent access and transition points. Maintenance of the plant has been perfected by using easy-to-access components and plenty of working space. These incline screens can be used as scalpers directly after primary crushers or as finishing screens. With production up to 1500 tph, these units are the highest performing inclined screen plants on the market.

LIPPMANN

**ADDITIONAL
INFORMATION**



HORIZONTAL SCREENS

A classic design of 6x20 and 8x20 triple-shaft, triple-deck screen box, mounted on chassis configuration with high tonnage capabilities. Features such as wide side conveyors with easy-access drives, reconfigurable bypass chutes and the widest fines conveyor on the market to minimize wall wear. These plants come complete and fully loaded with all the options to make operations easier, more efficient and reduce downtime.

LIPPMANN

**ADDITIONAL
INFORMATION**





FIXED EQUIPMENT

Lippmann's large-model Jaw Crushers are world-renowned, massive, heavy-duty machines designed for unmatched reliability, high capacity, and productivity in demanding mining applications. Compare a Lippmann with other jaw crusher brands: the shaft and other components are larger, and the frame is much heavier. They're built for demanding, high-volume crushing production and long-lasting strength. Lippmann equipment is engineered to operate reliably in the toughest mining environments. Our primary jaw units in gold ore mining applications, used in conjunction with secondary and tertiary cone plants, have received considerable acclaim.

LIPPMANN

**ADDITIONAL
INFORMATION**





***OVERSIZED. HEAVY DUTY.
CRUSHERS THAT ARE
BUILT TO LAST.***



FROM ROCK FACE TO LOAD OUT



LIBERTY JAW

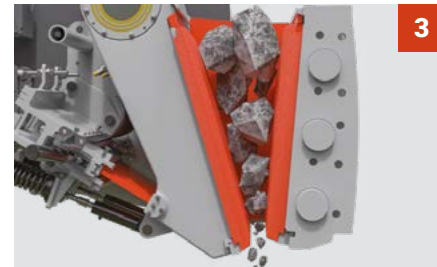

1. HYDRAULIC WEDGE ADJUSTMENT
2. JAW DIE LIFTING POINTS
3. AGGRESSIVE NIP ANGLE
4. PITMAN TOE PROTECTION
5. COMPOSITE DRIVE GUARD



ADDITIONAL
INFORMATION

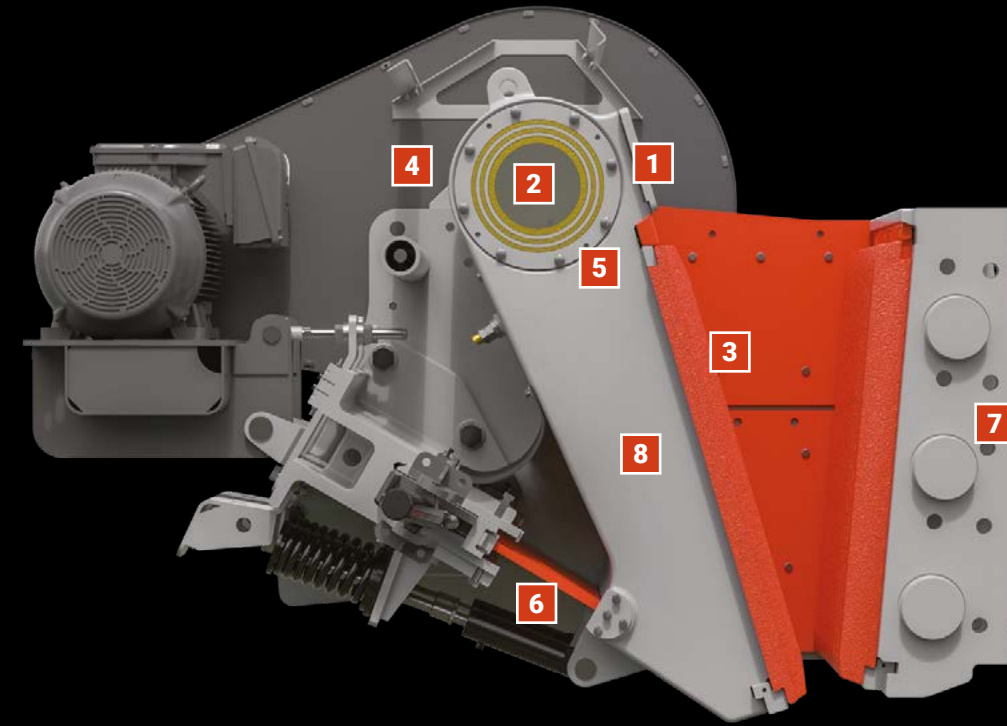

SPECIFICATIONS

1. REPLACEABLE BARREL LINER

Easily replaced and designed to protect the bearings and pitman housing.

2. HIGH STRENGTH ECCENTRIC SHAFT

This hardest working component is precision CNC-machined for proven high strength and reliability.

3. MINE DUTY JAW DIES

Offering different liner configurations expands the application window for the crusher.

4. SOLID CAST, HIGH INERTIA FLYWHEELS

Optimized design to generate the crushing force required for the toughest and hardest materials.

5. SPHERICAL ROLLER INBOARD/ OUTBOARD BEARINGS

Ensures the maximum performance providing the lowest cost of ownership.

6. HIGH STRENGTH TOGGLE PLATE

Provides the correct protection of the crusher to ensure performance and long term durability.

7. HIGH STRENGTH SOLID CASTING

Cast structural components, including end frames and a one-piece pitman, for a high strength machine.

8. ONE-PIECE CAST PITMAN

High strength solid casting.

LIBERTY JAW GENERAL SPECIFICATIONS

Model	Weight		Feed Opening		CSS		Capacity		Speed rpm	Max Feed Size		Power	
	kg	lbs	mm x mm	inch x inch	mm	inch	MTPH	STPH		mm	inch	kW	hp
2155B	16,500	36,400	530 x 1,400	21 x 55	40 - 130	1.6" - 5.1"	90 - 400	100 - 440	280	427	16.8"	110	150
2636B	14,050	31,000	650 x 900	26 x 36	60 - 160	2.4" - 6.3"	110 - 360	120 - 396	300	528	20.8"	75	100
3042B	15,700	34,600	750 x 1,070	30 x 42	70 - 200	2.75" - 8"	150 - 500	165 - 550	280	610	24.0"	110	150
3343B	22,300	49,200	830 x 1,100	33 x 43	80 - 200	3.2" - 8"	180 - 620	200 - 680	270	671	26.4"	110	150
3055B	26,950	59,000	760 x 1,400	30 x 55	70 - 200	2.75" - 8"	240 - 780	265 - 855	260	610	24.0"	160	200
3455B	31,500	69,445	860 x 1,140	34 x 48	100 - 200	4" - 8"	320 - 800	353 - 880	250	691	27.2"	160	200
3448B	28,000	62,000	860 x 1,220	34 x 48	70 - 200	2.75" - 8"	170 - 560	185 - 615	230	691	27.2"	160	200
4051B	42,000	92,600	1,010 x 1,300	40 x 51	100 - 200	4" - 8"	290 - 880	320 - 970	230	813	32.0"	160	200
4655B	52,500	115,800	1,160 x 1,400	46 x 55	150 - 250	6" - 10"	400 - 900	440 - 990	230	935	36.8"	200	300
5165B	71,250	157,100	1,290 x 1,650	51 x 65	150 - 270	6" - 10.5"	550 - 1,100	605 - 1,210	220	1,036	40.8"	250	350
6080B	135,000	297,000	1,525 x 2,030	60 x 80	200 - 300	8" - 12"	700 - 1,450	770 - 1,595	200	1,219	48.0"	400	500

PATRIOT CONE



1. RAISED CONE HEAD SEATING SURFACE
2. UNIVERSAL CRUSHING CHAMBER
3. TRAMP RELIEF SYSTEM
4. HIGH PIVOT POINT GEOMETRY
5. COUNTERCLOCKWISE COUNTERSHAFT

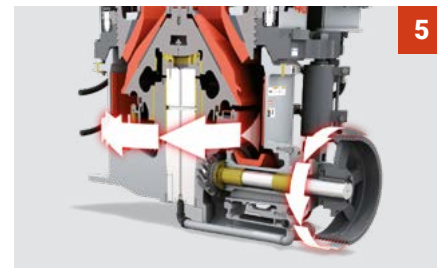
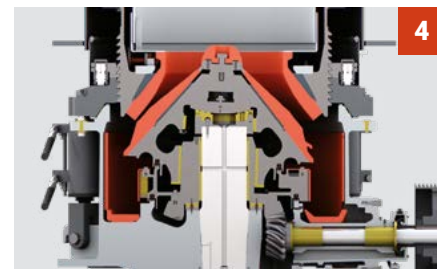
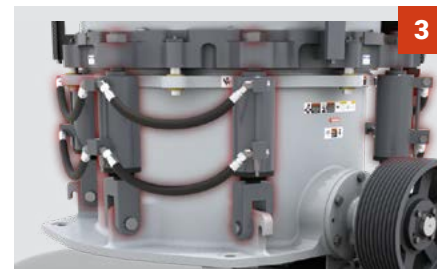
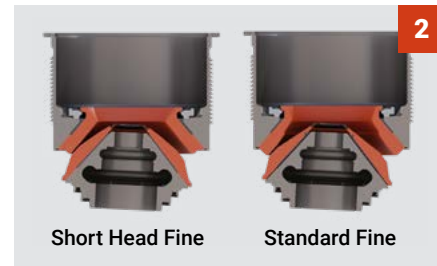

ADDITIONAL
INFORMATION



SPECIFICATIONS

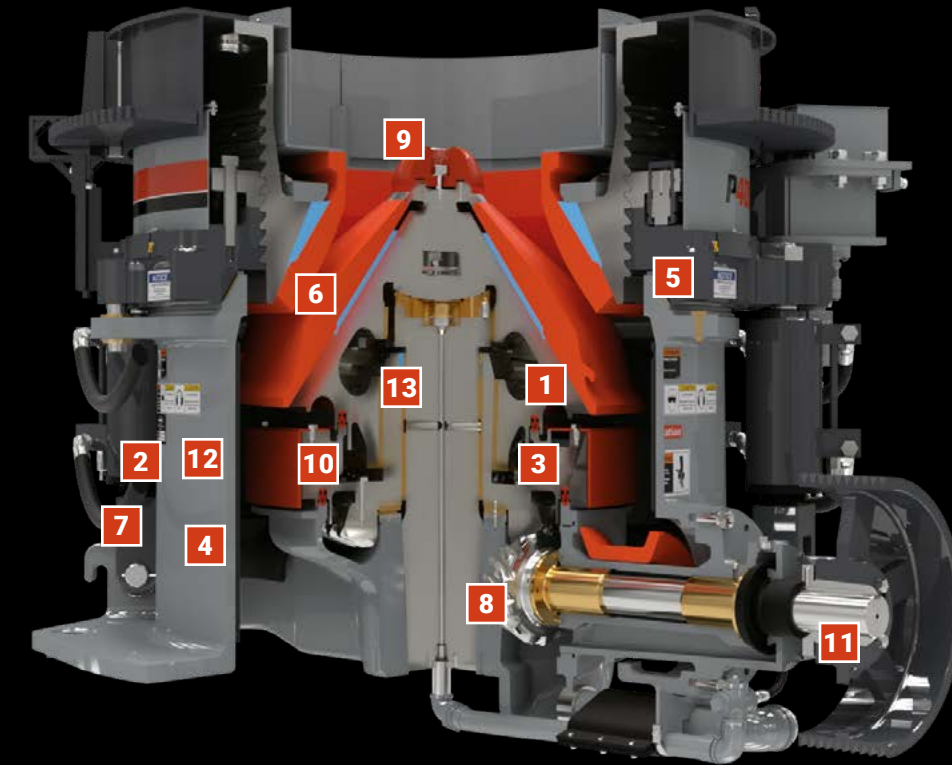

1. **RAISED CONE HEAD SEATING SURFACE**
Machined surface can be reconditioned up to 3X without need for additional welding.
2. **INVERTED TRAMP RELIEF CYLINDERS**
Reverse design ensures hydraulic seal is not exposed to contamination during operation.
3. **URETHANE "U" & "T" SEALS**
Opposed to steel, this non-contact seal blocks dust better, wears slower and takes less time to replace

4. **MAINFRAME INSPECTION PORTS (P200, P500, P600)**
Simplify access to mainframe for inspections.
5. **REPLACEABLE SEAT LINERS**
Bronze liners protect mainframe and adjustment ring from wear.
6. **UNIVERSAL CRUSHING CHAMBER**
Other than minor wear parts, design requires no major changeouts when transitioning from secondary and tertiary applications.
7. **TRAMP RELIEF SYSTEM**
Designed with fewer accumulators for less maintenance and failure points. Automatic pressure relief valve adds additional protection.

8. **SPIRAL TOOTH GEARING**
Proven to perform at higher speeds while causing less vibration and noise.
9. **HIGH PIVOT POINT GEOMETRY**
Movement of feedplate creates a more active feed opening, drawing more material into cavity with fewer plugs.
10. **ENCLOSED COUNTERWEIGHT**
Protects against the flow of material, which allows crusher to maintain balance. Guard provides additional wear protection.

11. **COUNTERCLOCKWISE COUNTERSHAFT**
If loss of clamping pressure, this unique rotation causes crusher to open rather than turn down, tighten and cause significant damage.
12. **ONE PIECE CAST MAINFRAME**
Removes any welding for highest possible strength and durability.
13. **ECCENTRIC & CLAMP RING**
Manufactured with ductile iron which has higher tensile and fatigue strength, resists fracturing and is more impact resistant.

SENTRY HSI



1. **CAST CLOSED ROTOR DESIGN**
2. **HYDRAULIC CURTAIN ADJUSTMENT**
3. **HYDRAULIC OPENING AND CLOSING**
4. **ROTOR LOCKING TOOL**
5. **FEED HOOD EXTENSION**

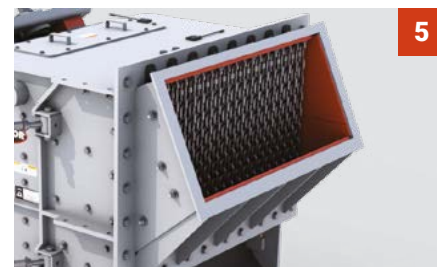
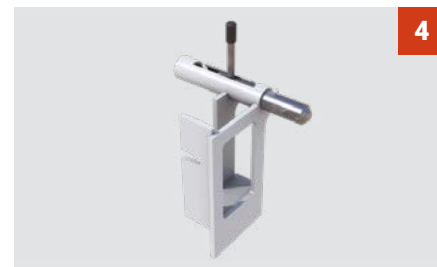
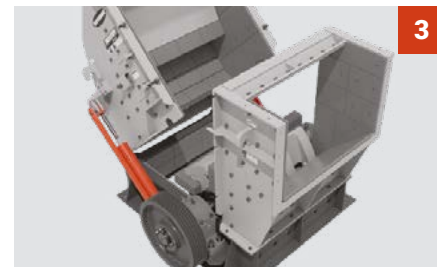

ADDITIONAL INFORMATION



SPECIFICATIONS

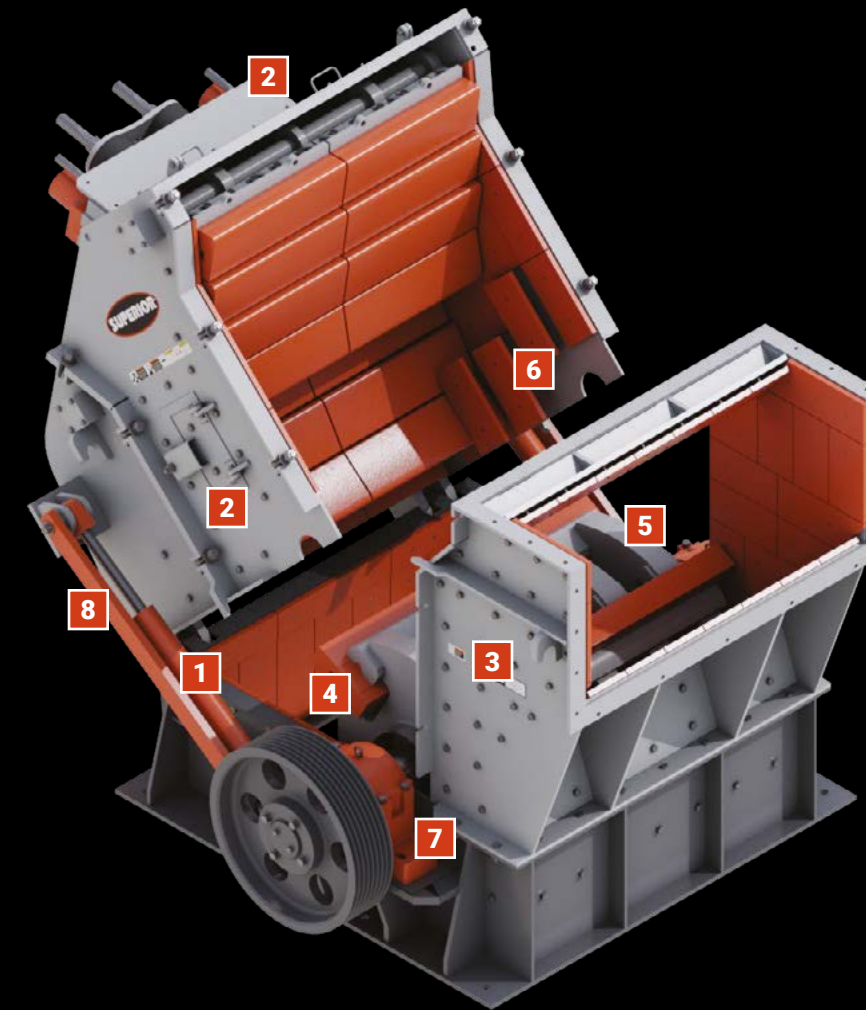

1. **HYDRAULIC OPENING & CLOSING**
Safely and simply access internal components for inspection.
2. **MAINFRAME INSPECTION DOORS**
Access the crushing chamber at additional locations including top, side and back inspection.
3. **REPLACEABLE UPPER FEED OPENING SECTION**
High wear area is easily replaceable.
4. **BLOW BARS**
Two or four blow bar rotor option with one or two-piece bars manufactured in a robust 4.5" (114 mm) minimum manganese or chrome.
5. **FIXED BLOW BAR CLAMPING**
Provides maximum clamping for best performance in hard rock applications.
6. **COMMONLY-SHAPED SIDE LINERS**
Mix and match these liners to prolong wear life and decrease cost of replacement components.
7. **OFF-THE-SHELF BEARINGS**
Local sourcing speeds access to parts in emergency situations.
8. **CRUSHER LID SAFETY LOCK**
Locks housing for safety during maintenance.

CEMCO VSI



1. **HYDRAULIC LID LIFTER**
2. **SINGLE OR DUAL DRIVE**
3. **EXTERNALLY ADJUSTED FEED TUBE**
4. **INTERCHANGEABLE CRUSHING CHAMBERS**
5. **VANTAGE® AUTOMATION**

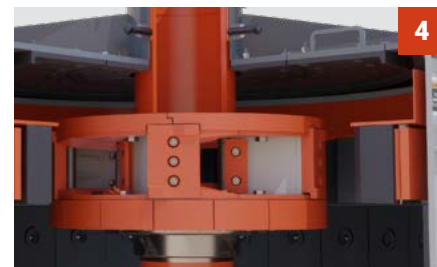
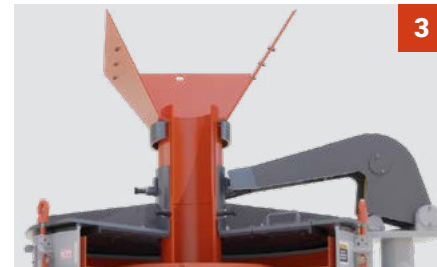

ADDITIONAL INFORMATION



SPECIFICATIONS

1. **HYDRAULIC LID LIFTER**
Hydraulic lid lifter and camloc system provide quick internal access.
2. **ADJUSTABLE FEED TUBE**
Wear-resistant adjustable feed tube maximizes throughput and insures all feed material is processed.
3. **CRUSHING CHAMBER**
Interchangeable crushing chamber supports multiple rotor and anvil ring configurations.
4. **ROTOR ASSEMBLY**
Replaceable pedestal style component can also be rebuilt in a shop environment.
5. **ANVIL RING**
Rotatable and count-adjustable anvil ring.
6. **SINGLE OR DUAL DRIVE**
Optional twin motor design minimizes cyclic vibration and correctly loads pedestal bearings.

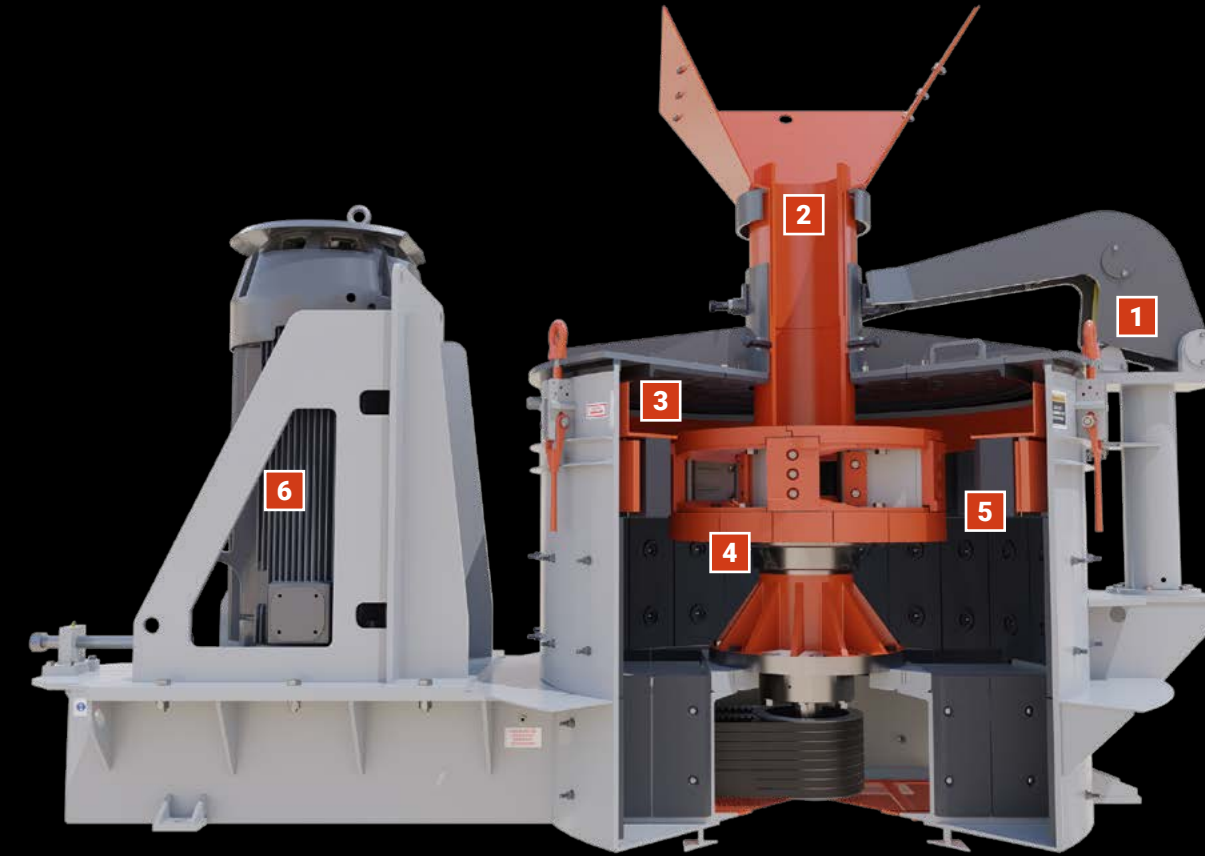

Typical Physical Properties

Model	Configuration	Max Feed Size		Table/Rotor Diameter		Capacity		Rotor/Table Operation range RPM	Typical HP Range		Max Weight	
		mm	inch	mm	inch	MTPH	STPH		kw	hp	kg	lbs
T35 Single	Rotor (4 Port)	25	1.0	457	18	9 - 45	10 - 50	2,000 - 2,600	56 - 75	75 - 100	2,495	5,500
	Shoe Table (4, 5 Shoe)	40	1.5	457	18	9 - 45	10 - 50	2,000 - 2,600	56 - 75	75 - 100	2,495	5,500
T54 Single	Rotor (4 Port)	40	1.5	686	27	45 - 113	50 - 125	1,200 - 1,950	112 - 187	150 - 250	4,990	11,000
	Shoe Table (4, 5 Shoe)	50	2.0	686	27	45 - 113	50 - 125	1,200 - 1,950	112 - 187	150 - 250	4,990	11,000
T70 Single	Rotor (4 Port)	50	2.0	813	32	45 - 136	50 - 150	1,200 - 1,850	149 - 224	200 - 300	7,030	15,500
	Shoe Table (4, 5 Shoe)	75	3.0	813	32	45 - 136	50 - 150	1,200 - 1,850	149 - 224	200 - 300	7,030	15,500
T80 Single or Dual	Rotor (5 Port)	65	2.5	889	35	90 - 250	100 - 275	1,200 - 1,650	225 - 300	300 - 400	8,777	19,350
	Shoe Table (4, 5, 6 Shoe)	100	4.0	889	35	90 - 250	100 - 275	1,200 - 1,650	450 - 600	600 - 800	11,430	25,200
C1920 Dual	Rotor (5 Port)	50	2.0	813 - 990	32 - 39	136 - 408	150 - 450	1,200 - 1,750	Dual	Dual	15,875	35,000
	Shoe Table (4 Shoe)	100	4.0	965	38	136 - 408	150 - 450	1,200 - 1,750	597	800	15,875	35,000



INTREPID FEEDER



Remove unwanted fines while providing a continuous feed to plant.

FEATURES

- Rugged design features greater I-beam support, precision shafts, and Huck fasteners
- Unique bottle jack lifting points allow for safer spring maintenance
- Adjustable slope and stroke to increase application flexibility and performance
- Patent-pending designs manufactured in widths to feed up to 1,400 stph (1,540 mtph)

ADDITIONAL
INFORMATION



GUARDIAN SCREEN



Accurate sizing and separation for construction aggregates and mining

FEATURES

- Heavy-duty construction handles 10" (254 mm) feed size and up to 4" (102 mm) openings
- Handles coarse and fine screening with adjustable oval stroke motion
- Side tension single crown decks
- Wet or dry screening configurations
- Various deck options are available including scalping, flat urethane/rubber, and end tension styles





ADDITIONAL
INFORMATION









PORTABLE PLANTS

3055

	JAW	30" x 55" (760 mm x 1 400 mm)
	HOPPER	10 yd ³ (7.5 m ³)
	MAIN CONVEYOR	60" (1 525 mm)
	DISCHARGE HEIGHT	8' (2.4 m)

TRANSPORTATION

	WEIGHT	70 000 lbs (31 700 kg) on 5th wheel 78 000 lbs (35 400 kg) on quad axle
	LENGTH	60' 9" (18.5 m)
	WIDTH	11' 11" (3.6 m)
	HEIGHT	14' (4.3 m)

1 HOPPER

- 3/4" AR lined
- 22' length

2 FEEDER

- 54"x20'
- Bolted 1/2" AR base
- Bolted 1/2" walls
- 40 hp drive

3 JAW

- 30"x 55" heavy duty jaw crusher
- Hydraulic wedge adjustment
- 200 hp integrated drive

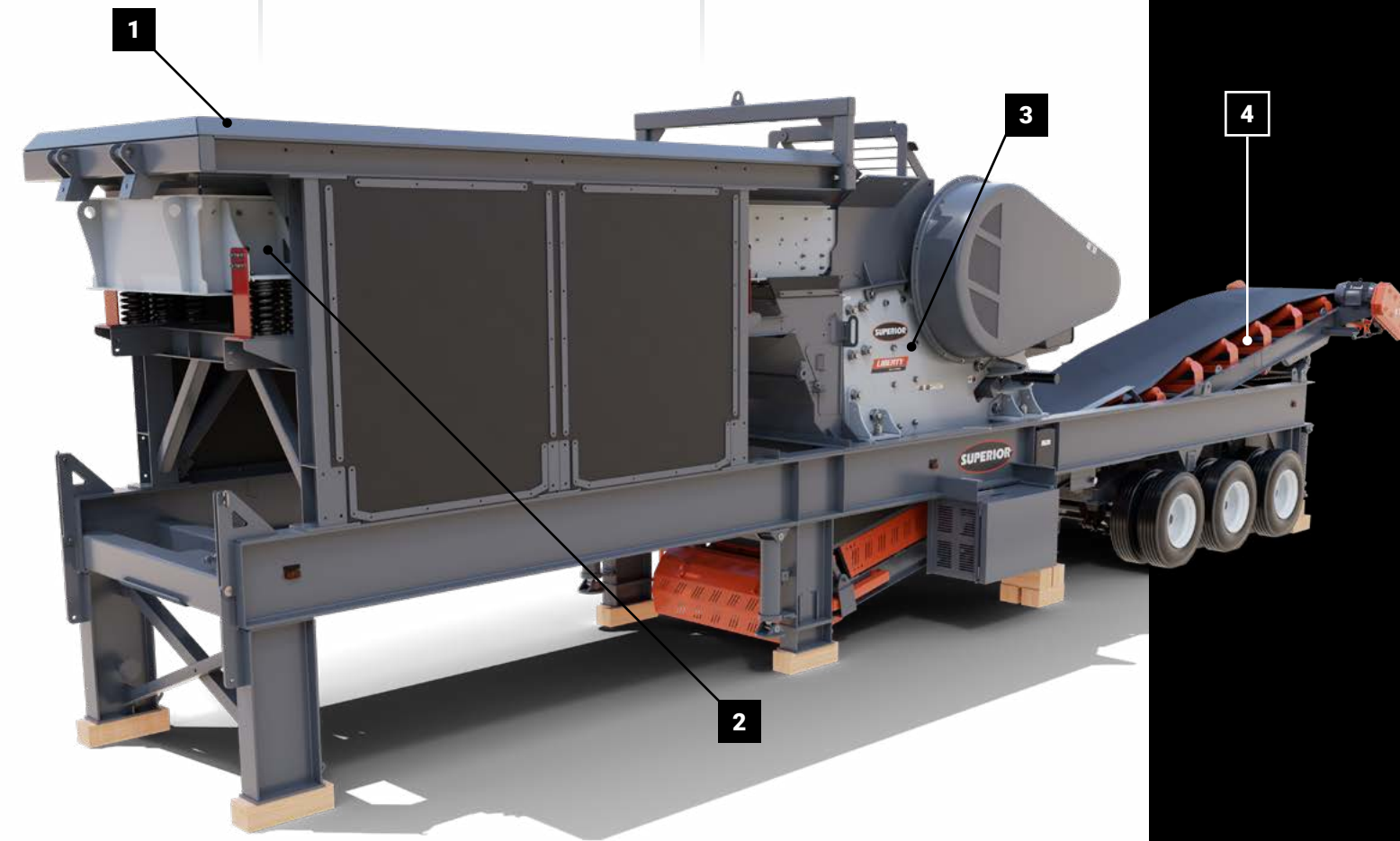

4 CONVEYOR

- 60" wide with 8' transfer height
- CEMA C impact rollers
- 500 tph
- 20 hp 90 degree drives

OPTIONS

- Run-on-jacks
- Hydraulic hopper extensions
- Magnet
- Control panel

SPECIFICATIONS

ADDITIONAL INFORMATION





PORTABLE PLANTS

P300cc6203

	CONE	P300 Patriot
	SCREEN	Guardian 6 x 20 3-deck horizontal screen
	MAIN CONVEYOR	42" (1 070 mm)

TRANSPORTATION

	WEIGHT	70 000 lbs (31 700 kg) on 5th wheel 78 000 lbs (35 400 kg) on quad axle
	LENGTH	60' 9" (18.5 m)
	WIDTH	11' 11" (3.6 m)
	HEIGHT	14' (4.3 m)

1 FEED CONVEYOR

- 42" wide
- Hydraulically folding 2 piece for cone access
- 5" CEMA C rollers
- Superior Exterra® Primary belt scraper
- 20 hp TEFC drive

2 SCREEN

- Guardian 6 x 20 3-deck horizontal screen
- 24" Feedbox with 1/4" AR liners
- 50 hp

3 FINES CONVEYOR

- 60" wide
- 15 hp TEF drive
- 5" CEMA C rollers
- Superior Exterra® Primary belt scraper

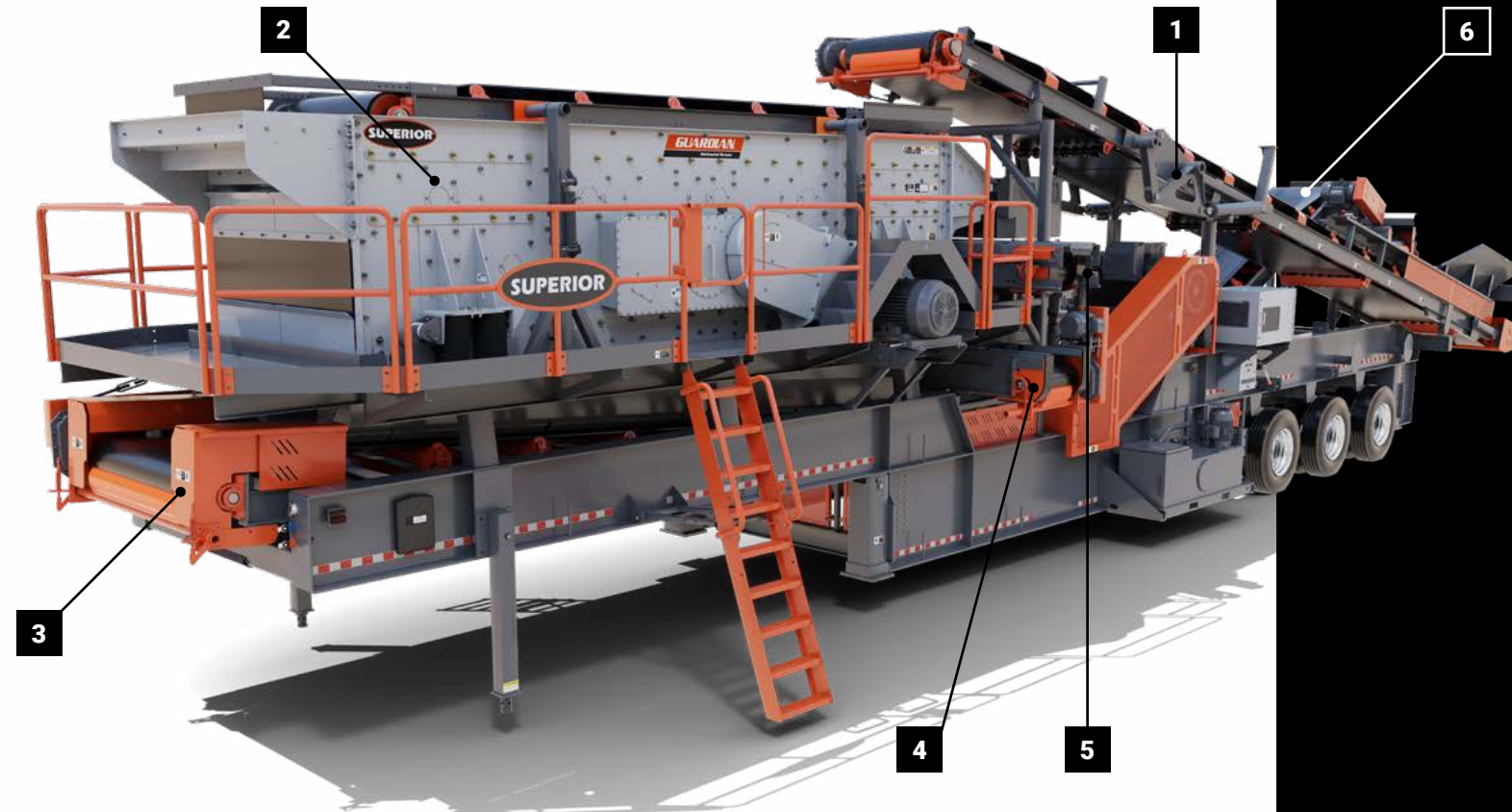

4 SIDE CONVEYORS

- Reversible net stone conveyors
- 7.5 hp TEFC
- CEMA C idlers

5 CRUSHER

- P300 Patriot
- Ultra sonic level sensor
- 300 hp TEFC drive
- Life Time Warranty with Vantage*

6 DISCHARGE CONVEYOR

- 36" wide
- 15 hp drive
- CEMA C rollers
- Superior Exterra® Primary belt scraper

SPECIFICATIONS

ADDITIONAL INFORMATION





PORTABLE PLANTS

P400RFRD

	CONE	P400 Patriot
	CONVEYORS	42" (1 070 mm)
	FEED HEIGHT	60" (1 525 mm)
	DISCHARGE HEIGHT	8' (2.4 m)

TRANSPORTATION		
	WEIGHT	70 000 lbs (31 700 kg) on 5th wheel 78 000 lbs (35 400 kg) on quad axle
	LENGTH	60' 9" (18.5 m)
	WIDTH	11' 11" (3.6 m)
	HEIGHT	14' (4.3 m)

1 FEED CONVEYOR

- 42" wide chanel frame
- 20 hp TEFC drive
- 5" CEMA C rollers
- Superior Exterra® Primary belt scraper

2 DISCHARGE CONVEYOR

- 42" wide chanel frame
- 20 hp drive
- 5" CEMA C rollers
- Superior Exterra® Primary belt scraper

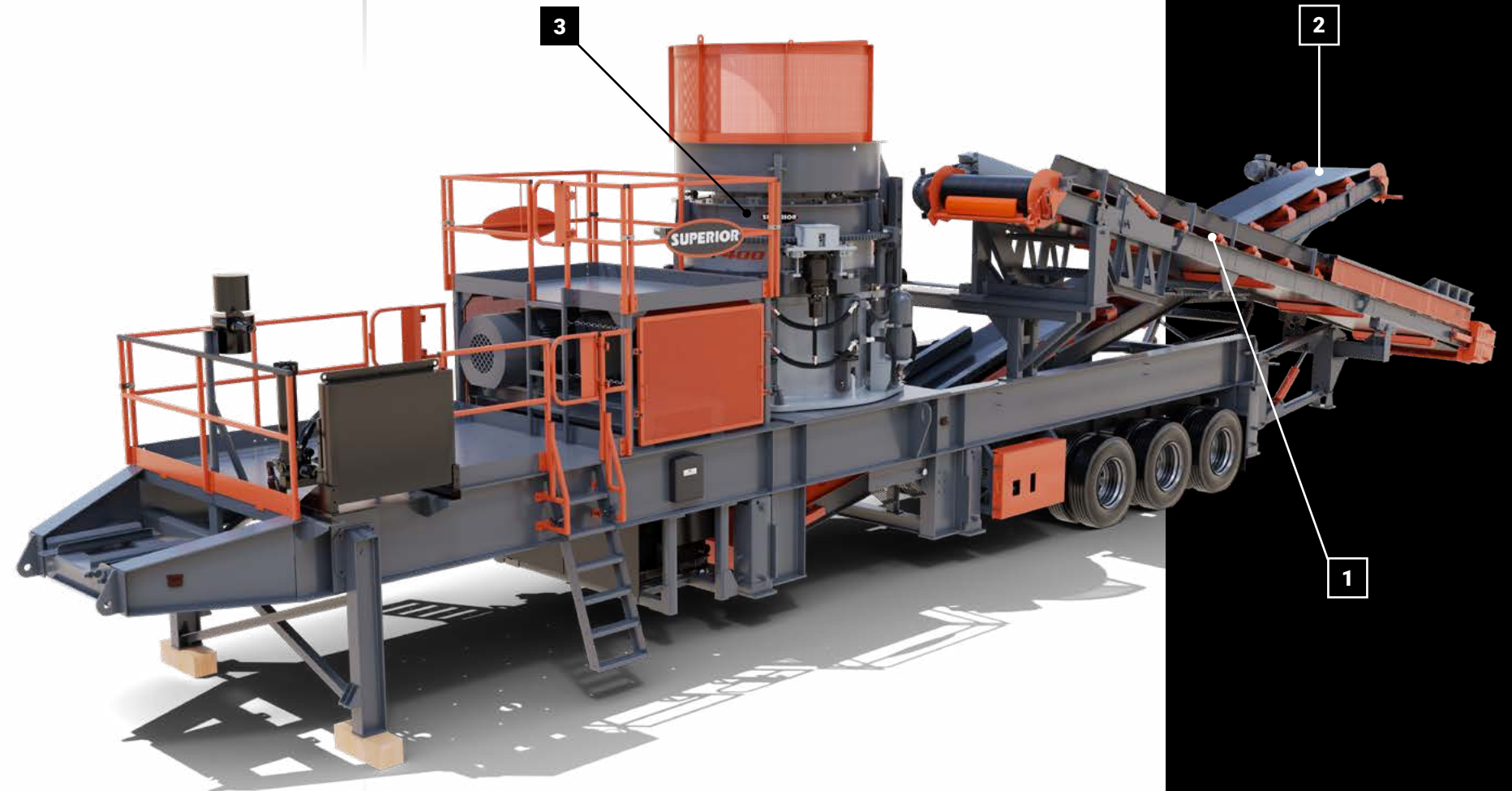

3 CONE

- P400 Patriot Cone Crusher
- 400 hp TEFC drive
- HPU & lube unit
- Life Time Warranty with Vantage*

OPTIONS

- Run-on-jacks
- Observation platforms
- Wide-Swing
- Vantage system

SPECIFICATIONS

ADDITIONAL INFORMATION









PORTABLE PLANTS

P500



-  **CONE** P500 Patriot Cone Crusher
-  **MAIN CONVEYOR** 48" (1 220 mm)

- TRANSPORTATION**
-  **WEIGHT** 58 000 lbs (26 300 kg) on 5th wheel
78 200 lbs (35 470 kg) on quad axle
 -  **LENGTH** 61' 2" (18.6 m)
 -  **WIDTH** 11' 11" (3.6 m)
 -  **HEIGHT** 13' 7" (4.1 m)

1 P500 PATRIOT CONE CRUSHER

- (2) 250 HP TEFC motors
- Counter shaft blower
- Lifetime warranty*

2 DISCHARGE CONVEYOR

- 48" (1.2 mm) wide
- 20 HP drive
- 5" (120 mm) CEMA C rollers
- Superior Exterra® Primary belt scraper

OPTIONS

- Run-On-Jacks
- Control Panel
- Vantage System

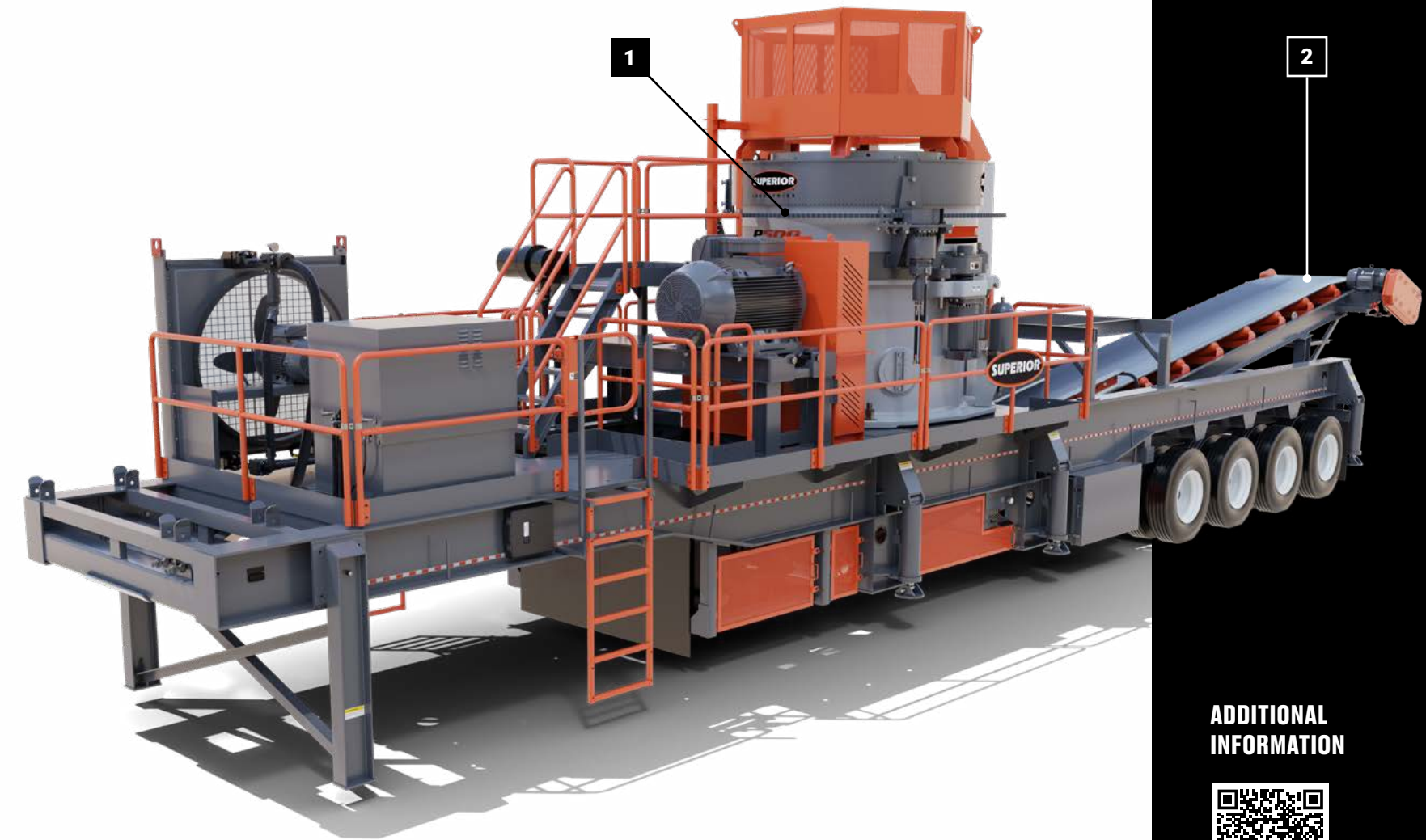

SPECIFICATIONS

ADDITIONAL INFORMATION











PORTABLE PLANTS

TANDEM 6203



-  **SCREENS** (2) 6' x 20' triple deck horizontal screens
-  **MAIN CONVEYORS** 30" (765 mm)
-  **SIDE CONVEYORS** 42" (1 070 mm)

- TRANSPORTATION**
-  **WEIGHT** 44 500 lbs (20 185 kg) on 5th wheel
77 500 lbs (31 150 kg) on quad axle
 -  **LENGTH** 71' (21.5 m)
 -  **WIDTH** 12' 5" (3.8 m)
 -  **HEIGHT** 14' 3/4" (4.5 m)

1 FEED CONVEYOR

- 30" wide (760 mm)
- 20 HP WEG electric drive motor
- Both splitting and transfer capability
- Lowers into screen boxes for transport

2 SCREEN BOXES

- (2) Guardian 6' x 20' (1.8 m x 6 m) 3 decks horizontal screens
- (2) 40 HP WEG electric drive motor
- Lip extensions on top deck

3 CROSS CONVEYORS

- 42" wide (1 050 mm)
- 10 hp TEFC drive motor
- Reversible
- Exterra® low pro mount scraper

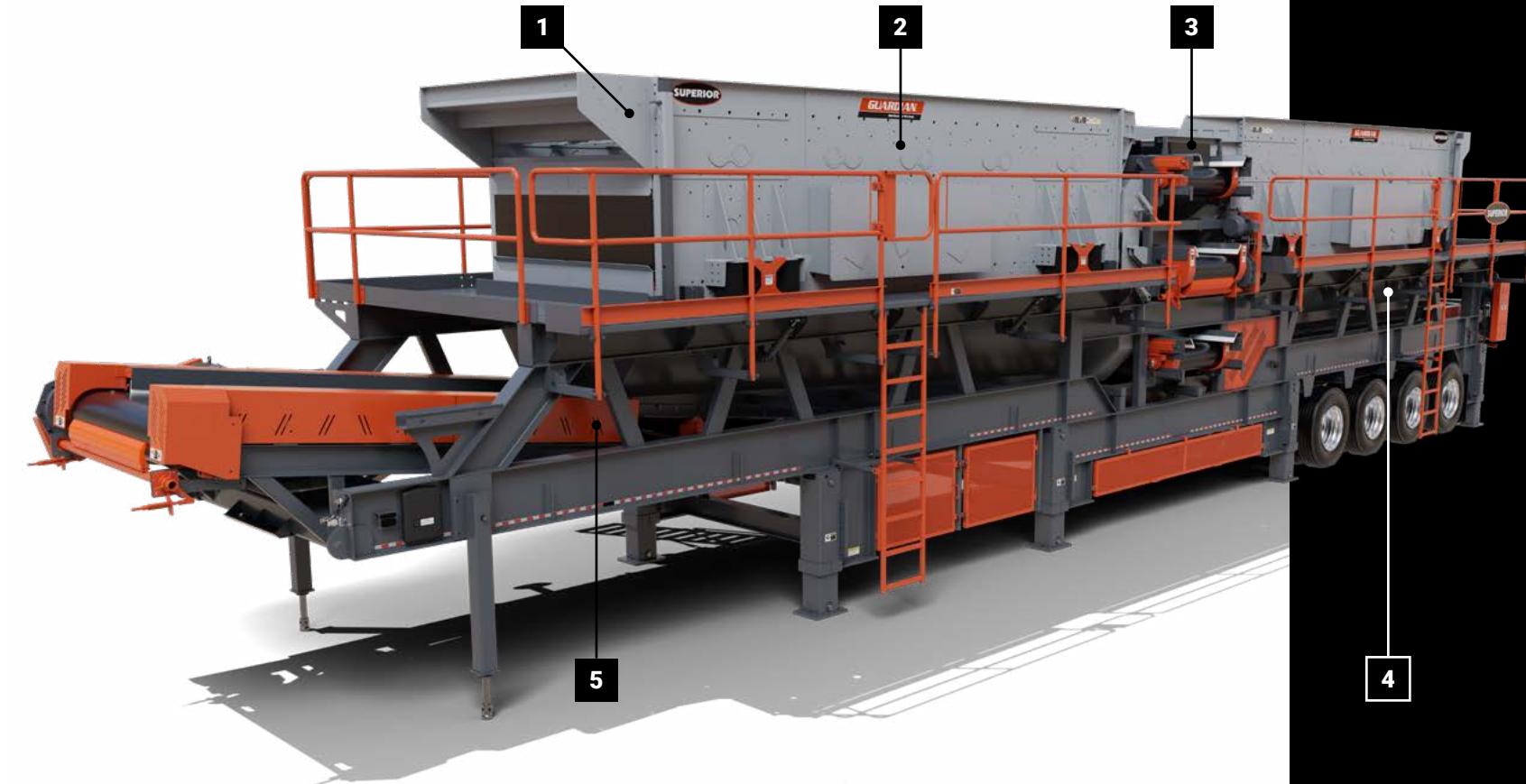

4 FINES DISCHARGE 1

- 60" wide (1 500 mm)
- 20 hp TEFC drive motor
- Reversible to discharge to Fines Conveyor 2
- Exterra® primary belt cleaner on both sides

5 FINES DISCHARGE 2

- 60" wide (1 500 mm)
- 20 hp TEFC drive motor
- Exterra® primary belt cleaner on both sides

OPTIONS

- Run-On-Jacks
- Control Panel

SPECIFICATIONS

ADDITIONAL INFORMATION





WASHING

Superior Industries offers a range of washing systems for a variety of industries. These systems are designed to help businesses reduce water consumption, minimize maintenance requirements, and achieve greater efficiency. Their modular design allows customization to meet the specific needs of each application. The systems can be adapted to handle a variety of materials and operating conditions, whether it's removing clay from sand or washing aggregate for concrete production.



**ADDITIONAL
INFORMATION**





CONVEYORS

Superior Industries is a leading manufacturer of a range of conveyor systems, including feed, transfer, overland, stockpile, and stationary conveyors. These systems are designed to move materials efficiently and reliably, reducing downtime and improving productivity. Superior Industries sets itself apart from other conveyor manufacturers by designing and building all the operating components of their conveyors in-house. From idlers and pulleys to scrapers and accessories, every part is 100 % Superior, resulting in highly reliable and durable systems.



**ADDITIONAL
INFORMATION**





TELESTACKERS

The TeleStacker conveyor stands as the world's best-selling telescopic conveyor, with over 1,400 units sold since its 1997 launch. Brilliantly designed, its variable length allows you to store in length rather than simply in a stack, minimizing the natural segregation of materials.



ADDITIONAL
INFORMATION





SHIP LOADING

Mobility is the key feature behind the ship loading configuration of Superior's famous TeleStacker Conveyor. Equipped with all-wheel steering, the portable ship loading conveyor achieves five modes of transportation including crab, radial, carousel, inline and parallel movements. It'll go anywhere you want it to!



ADDITIONAL
INFORMATION

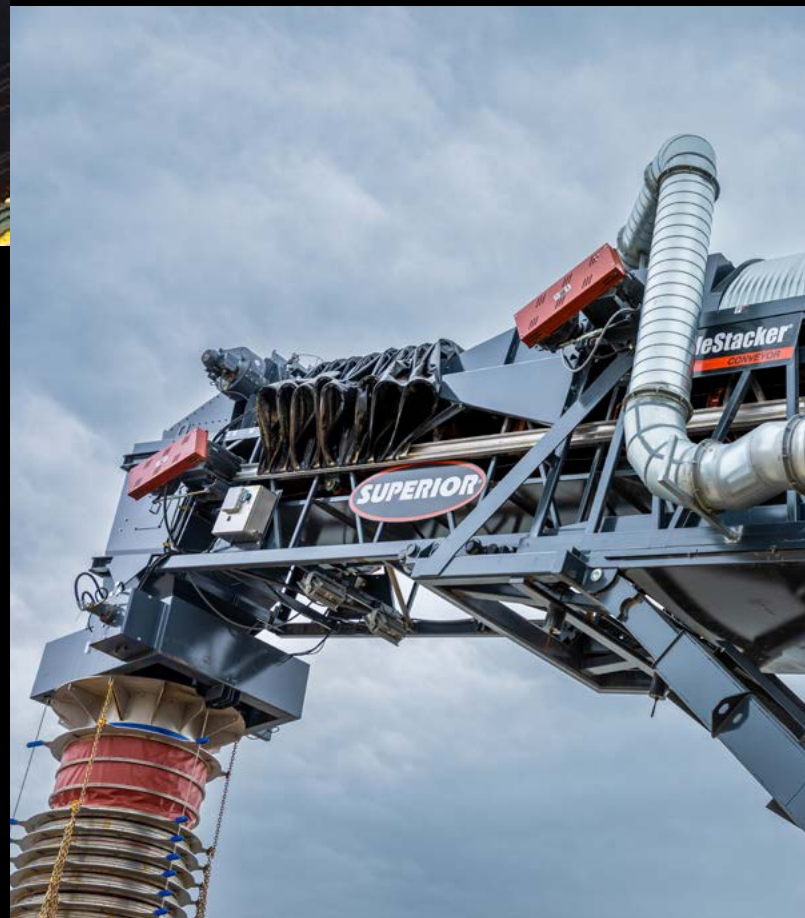



FUSION PLANT

Superior's modular platform systems offer bulk producers a faster, more economical solution to developing and commissioning a new processing plant. The scalable, pre-engineered systems offer convenient maintenance features and integrate seamlessly with Superior's crushing, screening, washing and conveying products.



ADDITIONAL INFORMATION



FEATURES AND BENEFITS

- Pre-Engineered systems
- Design flexibility
- Freight packaging
- Scalable solutions
- Swift commissioning

- CRUSHING
- SCREENING
- WASHING
- CONVEYING



AULT

EXCLUSIVE DISTRIBUTOR

McCloskey
INTERNATIONAL

MWS 
EQUIPMENT

LIPPMANN





AULT

PERFORMANCE PARTS
SERVICE SUPPORT

WWW.AULT.CA INFO@AULT.CA
1.855.300.2858 (AULT)

JACKSON AULT

President
514.826.0925

ONTARIO

2000 Technology Drive
Peterborough (Ontario)
K9J 6X7

Sales 416.559.9832
Parts 705.957.0925
Service 705.313.5003

QUEBEC

30 rue Nadeau
Waterloo (Quebec)
J0E 2N0

Sales 514.826.0925
Parts 819.342.3023
Service 450.830.2492

MARITIMES

275 Price Street
Moncton (New-Brunswick)
E1A 2L2

Sales 902.452.1273
Parts 506.321.6895
Service 506.588.4846