

AULT BUILT FOR WORK.

CATALOGUE

**BIOMASS,
COMPOST
AND RECYCLING**



MCCLOSKEY

ECOVERSE

TERRACON



AULT

A BUSINESS BUILT FROM THE GROUND UP.

AULT is one of North America's best-performing equipment suppliers. For more than 15 years, we have been providing our customers with state-of-the-art equipment and the fastest, most efficient service possible.

We are an exclusive distributor of brands recognized as industry leaders: McCloskey International (with whom we have worked since our inception), Lippmann, MWS, Superior, Ecoverse and Terracon. For your project, we offer only the best. The best products supported by unrivalled service.

We don't just sell machines. We're a partner in your project. We're a part of your team.

This is our line of work.

Here's what we sell, what we maintain, what we support.

OUR PRODUCTS AND SERVICES ARE BUILT FOR WORK.



TABLE OF CONTENTS

EDITION 02/2026

4	SUPPORT AND SERVICE	26	ECOVERSE
6	WEAR PARTS	28	DOPPSTADT
8	MCCLOSKEY INTERNATIONAL	34	BACKHUS
10	512 A/R/E/T/G	36	MENART
12	516 R/E/T/G	38	BACKERS
14	621RE/G	40	ECOSIFT
16	733RE	42	TIGER DEPACK
18	R-155	44	CK INTERNATIONAL
20	R-230	46	TERRACON
22	ST80 T/V/L/A	48	MAVERICK 224
24	SF80	50	4065T

SUPPORT AND SERVICE

HERE'S WHO YOU'LL BE WORKING WITH.
THIS IS OUR TEAM IN THE FIELD.



CONTACT OUR EXPERTS

1-855-300-AULT
info@ault.ca
www.ault.ca



AULT is a dedicated team of passionate experts.

Our advisors, engineers, and mechanics have been committed to the success of your projects and, ultimately, your business. Regardless of the challenge or the timeframe, you can rely on AULT's team across Ontario, Quebec, and the Maritimes to get the job done.

AULT's sole focus is our wide range of specialized processing equipment. Whether its mineral processing, quarries, pits, recycle, or composting, our team has the knowledge base and experience to help your operation run efficiently.

We make sure to maintain and support your equipment as if it were our own. By entrusting us with the maintenance and support of your equipment, you are assured that they will remain reliable, efficient, and long-lasting.

Our machines won't let you down, and our team will make sure of it.



WEAR PARTS

**BUILT TO LAST,
MADE TO PERFORM.**

At Ault, we provide the best parts to tackle the toughest conditions. Designed to endure and exceed your expectations, they deliver unmatched performance and reliability.

Each part is certified, tested, and ready to take on the challenges of your most demanding operations.

FIND YOUR PARTS

MATTHEW RESTOULE
Aftermarket Specialist
(514) 992-7155
matthew@ault.ca

SHREDDER AND GRINDER WEAR PARTS

- High speed and low speed teeth
- Knives / Blades / Counter knives
- Hammers

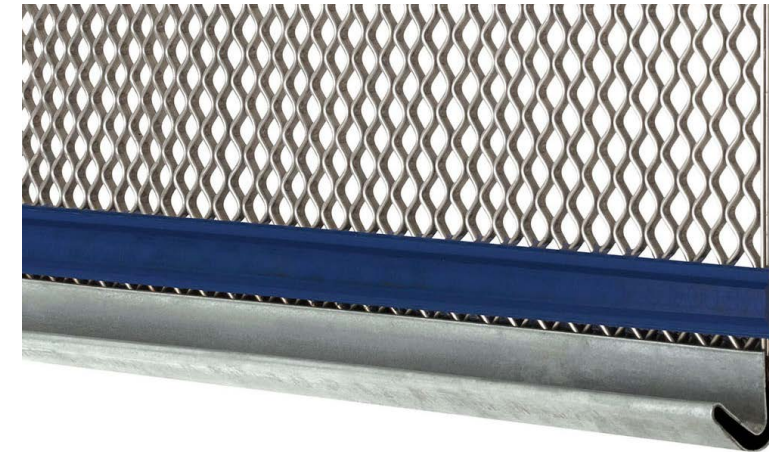

SCREENER PARTS

- Self-cleaning screens
- Woven wire
- Punch plates
- Finger deck assemblies
- Trommels drums and screens
- Rollers
- Scraper assemblies

OTHER PARTS

- Conveyors and stackers
- Windrow turners
- Belts and drive systems
- Hydraulic and adjustment components
- Magnetic liners
- Canoe liners



FIELD TESTED WORLDWIDE



McCloskey
INTERNATIONAL



TROMMELS

512 A/R/E/T/G

McCloskey
INTERNATIONAL

As the top-selling mid-size portable trommel in North America, the 512 offers a combination of high production rates, versatility, ease-of-use, and unrivaled strength that has ensured this screener's popularity with topsoil producers, compost facilities, and sand & gravel pits.

1 POWER PACK

- CAT C2.8 (74 hp)

optional

- CAT 3.6 (100 hp)
- Electric hydraulic power
- Auxiliary drive circuit (PTO)
- Automatic reversible fan

2 FEEDER

- 30" (760 mm) adjustable speed hot-spliced belt

optional

- Tipping grid ready
- Hydraulic tipping grid over hopper - Includes spill plate

3 TROMMEL

- Screened drum 5' x 12' (1.5 m x 3.6 m)
- 4 x 4 drive system

optional

- Trommel brushes double side
- Stainless steel screens

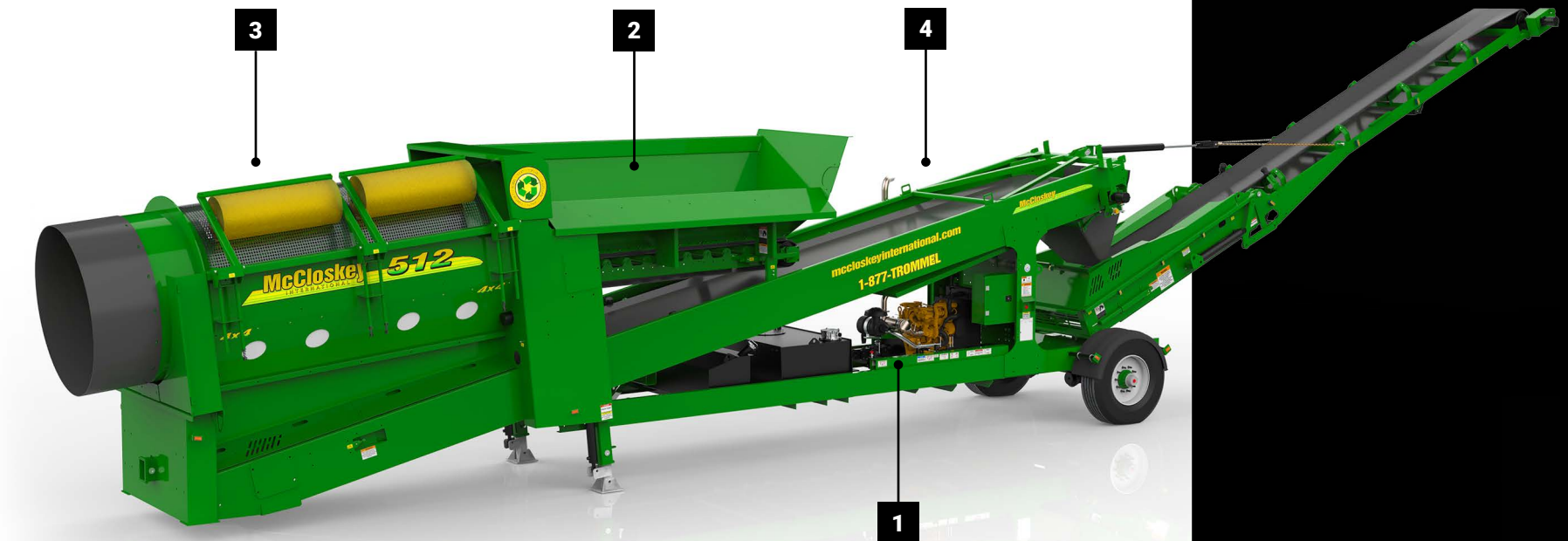

4 CONVEYORS

- Hot-spliced fines collection 48" (1.2 m)

optional

- 180° integrated radial stockpiling conveyor 600 yd³
- hydraulic folding hot-spliced chevron end conveyor 30" (760 mm)

OTHER OPTIONS

- Tracked unit with end conveyor and wireless remote control

SPECIFICATIONS

ADDITIONAL INFORMATION





TROMMELS

516 R/E/T/G

McCloskey
INTERNATIONAL

McCloskey offers a wide range of drum designs and screen sizes to improve quality and meet high demand. The 516 models boosts your operational efficiency, reducing costs without sacrificing production and performance. It is perfect where environmental, legislative, or noise constraints are a consideration.

1 POWER PACK

- CAT C2.8 (74 hp)

optional

- CAT 3.6 (100 hp)
- Electric hydraulic power
- Auxiliary drive circuit (PTO)
- Automatic reversible fan

2 FEEDER

- 30" (760 mm) adjustable speed hot-spliced belt

optional

- Tipping grid ready
- Hydraulic tipping grid over hopper - Includes spill plate
- Remote start/stop feeder

3 TROMMEL

- Screened drum 5' x 16' (1.5 m x 4.8 m)
- 4 x 4 drive system

optional

- Trommel brushes double side
- Stainless steel screens

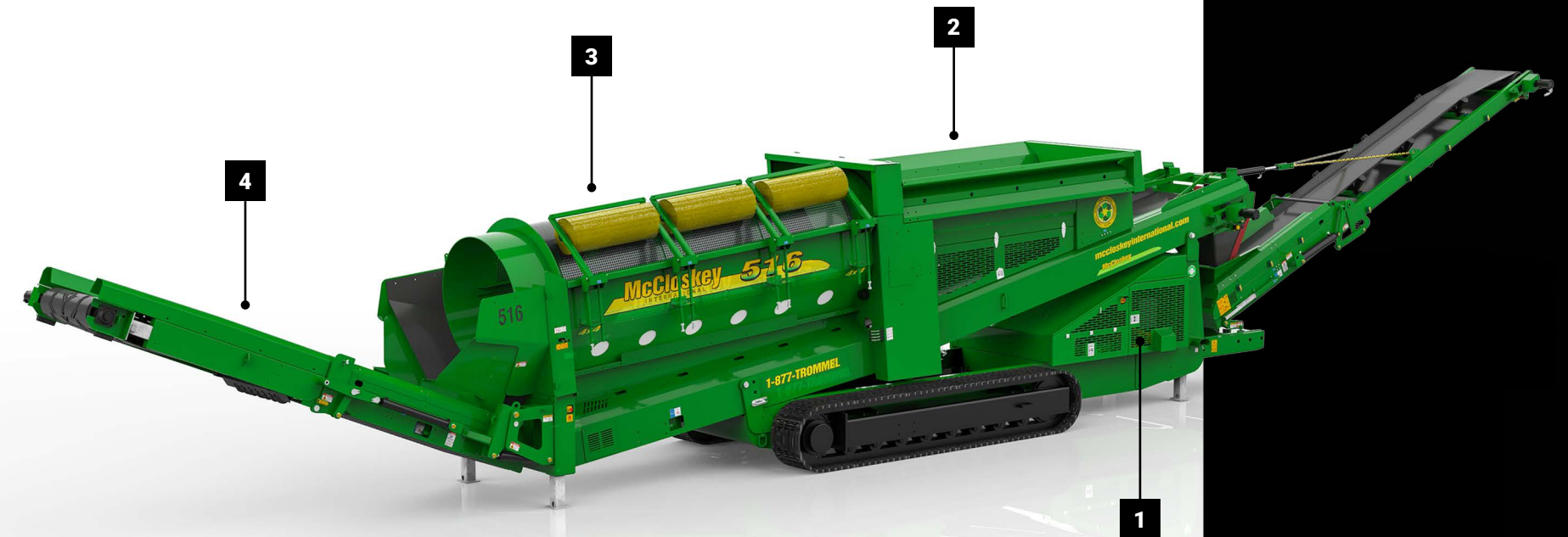

4 CONVEYORS

- Hot-spliced fines collection 48" (1.2 m)

5 OTHER OPTIONS

- Tracked unit with end conveyor and wireless remote control

SPECIFICATIONS

ADDITIONAL INFORMATION





TROMMELS

621RE/G

The 621 Trommel has established a proven reliability in construction and demolition, topsoil, compost, waste recycling, and many other large screening applications. With a 175 hp engine, accessible engine bay, and high-efficiency diesel hydraulic system, the 621 is sure to deliver the maximum operating time.

McCloskey
INTERNATIONAL

1 POWER PACK

- Volvo D5 (218 hp)

optional

- CAT C4.4 - 175 hp
- Electric hydraulic power
- Auxiliary drive circuit (PTO)
- Dual power diesel/electric
- Automatic reversible fan

2 FEEDER

- 42" (1 m) adjustable speed hot-spliced belt

optional

- Tipping grid ready
- Single or double deck live head with spill plate
- Remote start/stop feeder

3 TROMMEL

- Screened drum 6' x 21' (1.8 m x 6.4 m)
- 4 x 4 drive system

optional

- Trommel brushes double side
- Stainless steel screens

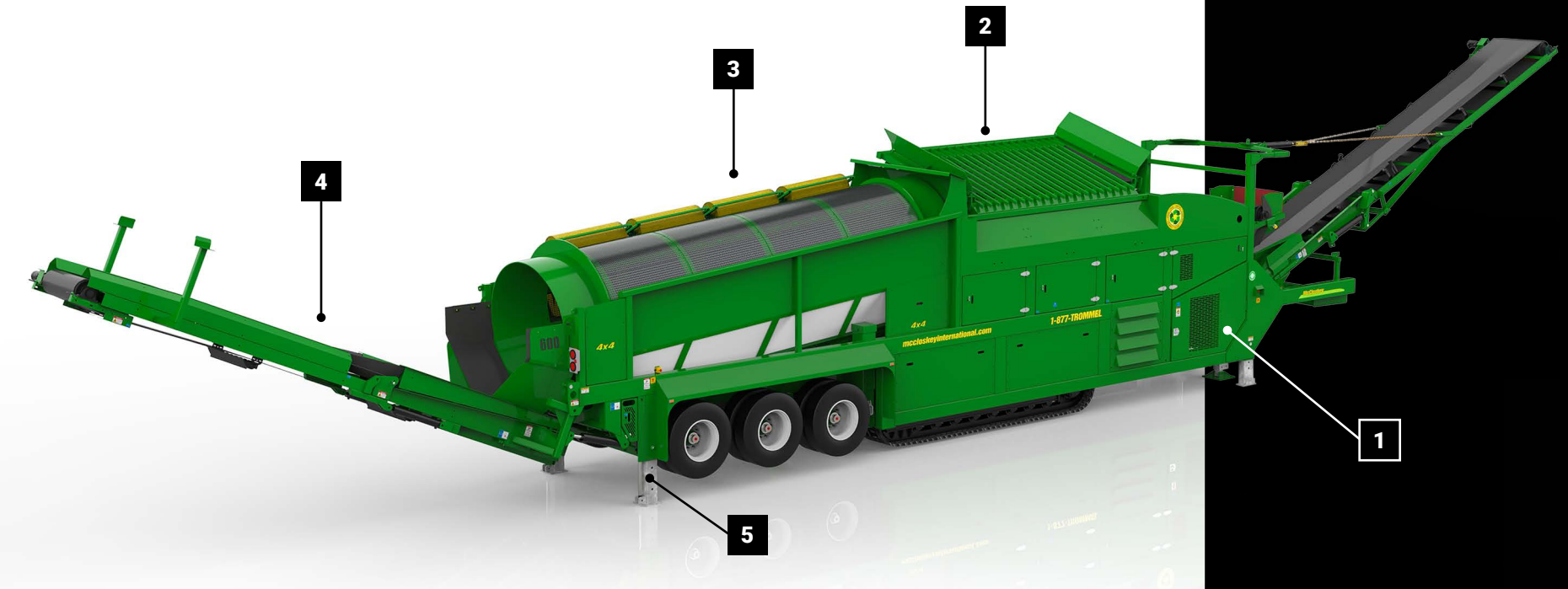

4 CONVEYORS

- Hot-spliced fines collection 42" (1 m)
- 180° integrated radial stockpiling conveyor 42" (1 m) 650 yd³ (450 m³)
- Hydraulic folding hot-spliced chevron end conveyor 36" (900 mm)

5 OTHER OPTIONS

- Tracks
- 4 hydraulic stabilizing legs for quick set-up

SPECIFICATIONS

ADDITIONAL INFORMATION





TROMMELS

733RE

The McCloskey 733 trommel screeners are high-production machines with a 160° radial fines conveyor and an oversize end conveyor for extensive stockpiling capabilities. Also available in dual power, the 733 boasts a 225 hp engine powering the world's highest-capacity mobile trommel.

McCloskey
INTERNATIONAL

1 POWER PACK

- Volvo D5 (218 hp)

optional

- CAT C4.4 - 175 hp
- Electric hydraulic power
- Auxiliary drive circuit (PTO)
- Dual power diesel / electric
- Automatic reversible fan

2 FEEDER

- 48" (1 m) adjustable speed hot-spliced belt

optional

- Tipping grid ready
- Single or double deck live head with spill plate
- Remote start/stop feeder

3 TROMMEL

- Screened drum 7' x 33' (2.1 m x 6.4 m)
- 4 x 4 drive system

optional

- Trommel brushes double side
- Stainless steel screens

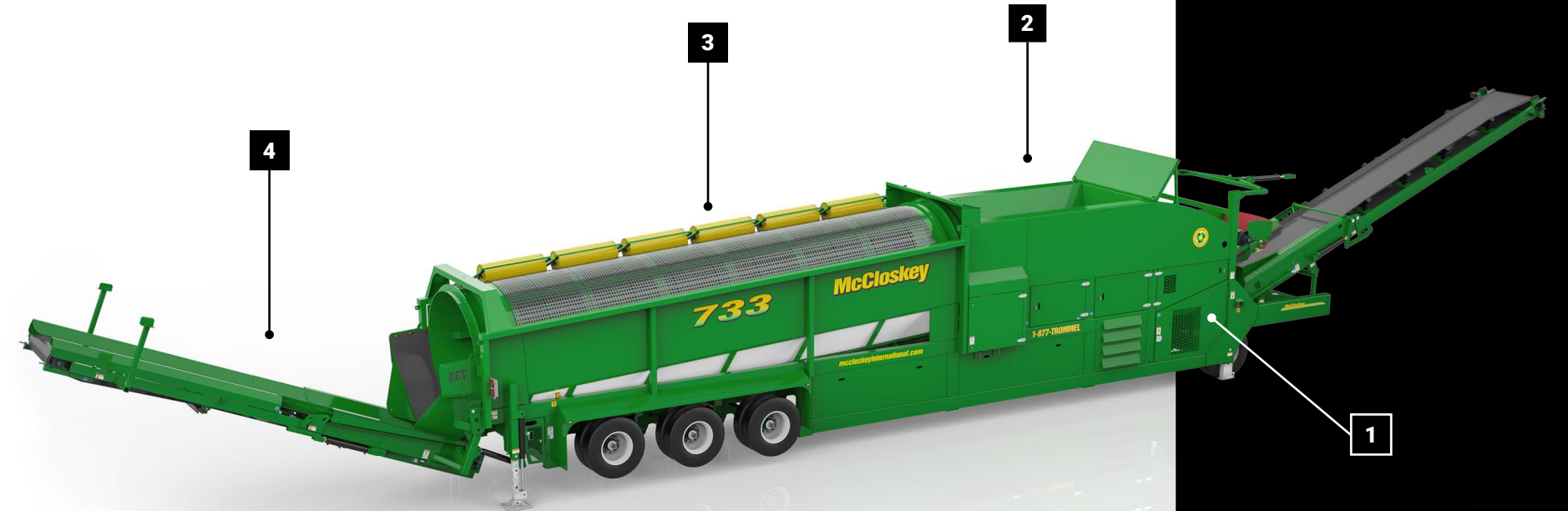

4 CONVEYORS

- Hot-spliced fines collection 54" (1.4 m)
- 160° integrated radial stockpiling conveyor 48" (1.2 m) 700 yd³ (535 m³)
- Hydraulic folding hot-spliced chevron end conveyor 48" (1 m)

SPECIFICATIONS

ADDITIONAL INFORMATION











SCALPERS R-SERIES

R-155

McCloskey
INTERNATIONAL

	POWER PACK	CAT C4.4 (131 hp)
	SCREEN BOX	5' x 16' (1.5 m x 4.9 m)
	HOPPER	10 yd ³ (8 m ³)
	FINES DISCHARGE	13' (4.0 m)
	MIDS DISCHARGE	11' 10" (3.6 m)
	OVERS DISCHARGE	13' 3" (3.5 m)

TRANSPORTATION

	WEIGHT	74 800 lbs (34 000 kg)
	LENGTH	50' 2" (15.3 m)
	WIDTH	9' 6" (2.9 m)
	HEIGHT	11' 2" (3.4 m)

1 POWER PACK

- CAT C4.4 (131 hp)

optional

- Dual power electric and diesel hydraulic
- Auxiliary drive circuit (PTO)
- Diesel fired cold weather package (CAT)

2 FEED HOPPER

- 10 yd³ (8 m³) hopper with 3 ply heavy duty feed belt 48" (1.2 m)
- Hardox® 450 liner
- Hydraulic folding extended hopper wing plates 15' (4.6 m) wide

optional

- High volume hopper 14 yd³ (10.7 m³)
- Extended low-load height feeder 15' (4.6 m) wide
- Steel apron plate feeder

3 SCREENBOX

- High-Energy™ screenbox 5' x 16' (1.5 m x 4.9 m)

optional

- Flex-flow style double deck screen box



4 CONVEYORS

- Independent pump sections for each conveyor
- Flat belt on fines collection 48" (1.2 m)
- Flat belt on fines discharge with spring loaded poly cleaner 36" (900 mm)
- Flat belt on mid product 36" (900 mm)
- Chevron belt on tail 55" (1.4 m)

optional

- Dust suppression system
- Screen blanket
- Reverse discharge side of fines and/or mid-product conveyor
- Twin drive on the tail conveyor
- Change flat belts to chevron belts (side conveyors)
- Extended tail conveyor
- Overband magnet on tail conveyor

OTHER FEATURES

- Removable track control c/w cable
- Remote machine shut off

optional

- Remote start/stop feeder
- Variable speed & start stop feeder kit
- Working lights
- Safety beacon lights
- Chain curtain (on top deck discharge)

SPECIFICATIONS

ADDITIONAL INFORMATION













SCALPERS R-SERIES

R-230

McCloskey
INTERNATIONAL

 POWER PACK	Volvo D5 (218 hp) / CAT C7 (225 hp)
 SCREEN BOX	6' x 20' (1.8 m x 6.1 m)
 HOPPER	14 yd ³ (10.7 m ³)
 FINES DISCHARGE	13' 6" (4.1 m)
 MIDS DISCHARGE	12' (3.7 m)
 OVERS DISCHARGE	12' 6" (3.8 m)

TRANSPORTATION

 WEIGHT	83 600 lbs (38 000 kg)
 LENGTH	55' 8" (17 m)
 WIDTH	9' 10" (3 m)
 HEIGHT	11' 5" (3.5 m)

1 POWER PACK

- Volvo D5 (218 hp)

optional

- CAT C7 (225 hp)
- Auxiliary drive circuit (PTO)
- Dual power electric and diesel hydraulic
- Diesel fired cold weather package (CAT)

2 FEED HOPPER

- 14 yd³ (10.7 m³) hopper with 3 ply heavy duty feed belt 60" (1.5 m)
- Hardox® 450 liner
- Hydraulic folding extended hopper wing plates 17' (5.2 m) wide

optional

- High volume hopper 18 yd³ (13.8 m³)
- Extended low-load height feeder 17' (5.2 m) wide
- Steel apron plate feeder

3 SCREENBOX

- High-Energy™ screenbox 6' x 20' (1.8 m x 6.1 m)

optional

- Flex-flow style double deck screen box

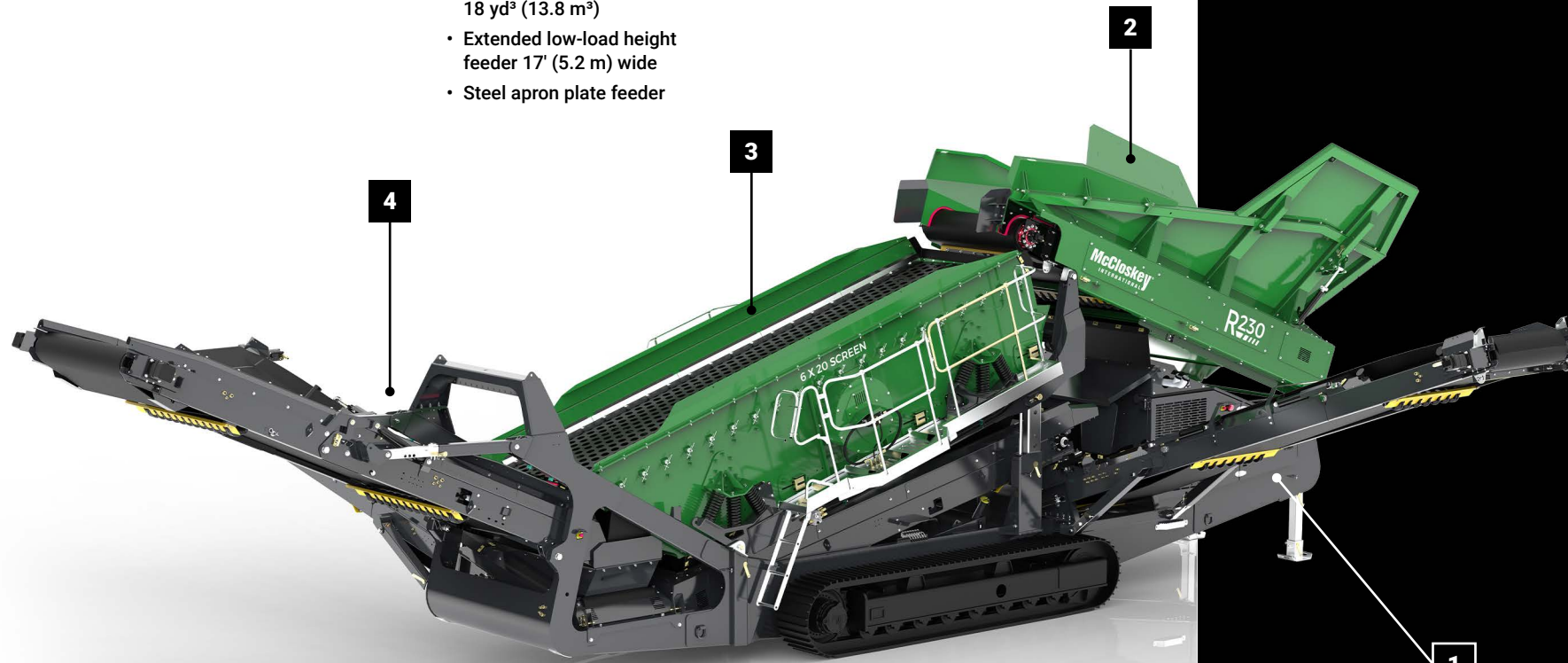

4 CONVEYORS

- Independent pump sections for each conveyor
- Flat belt on fines collection 55" (1.4 m)
- Flat belt on fines discharge with spring loaded poly cleaner 42" (1 m)
- Flat belt on mid product 36" (900 mm)
- Chevron belt on tail 64" (1.6 m)

optional

- Dust suppression system
- Screen blanket
- Reverse discharge side of fines and/or mid-product conveyor
- Twin drive on the tail conveyor
- Change flat belts to chevron belts (side conveyors)
- Extended tail conveyor
- Overband magnet on tail conveyor

OTHER FEATURES

- Removable track control c/w cable
- Remote machine shut off

optional

- Remote start/stop feeder
- Variable speed & start stop feeder kit
- Working lights
- Safety beacon lights
- Chain curtain (on top deck discharge)

SPECIFICATIONS

ADDITIONAL INFORMATION





CONVEYORS

ST80 T/V/L/A

McCloskey
INTERNATIONAL

The world's most successful portable stacker model is available with a wide variety of options to accommodate all operations and transport requirements. The ST80 is known for its incredible value and reputation for reliability.

1 POWER PACK

- Kubota V2208 (49 hp)

optional

- CAT C2.8 (74 hp)
- Electric tefc 25 hp heavy duty high efficiency 1750 RPM
- Electrical panel
- Hydraulics upgraded to 750 TPH (includes CAT C2.8 - 74 hp)

2 HOPPER

- Standard hopper 6' (1.8 m) width
- Hopper extensions 9' (2.7 m) width

optional

- Direct feed v-bin (c/w landing gear & CAT C2.8 - 74 hp)
- Impact idlers under hopper
- Hopper wear plates

3 BELT

- 3 ply - 3/16 x 1/16 (57 mm x 19 mm)

optional

- 3 ply chevron

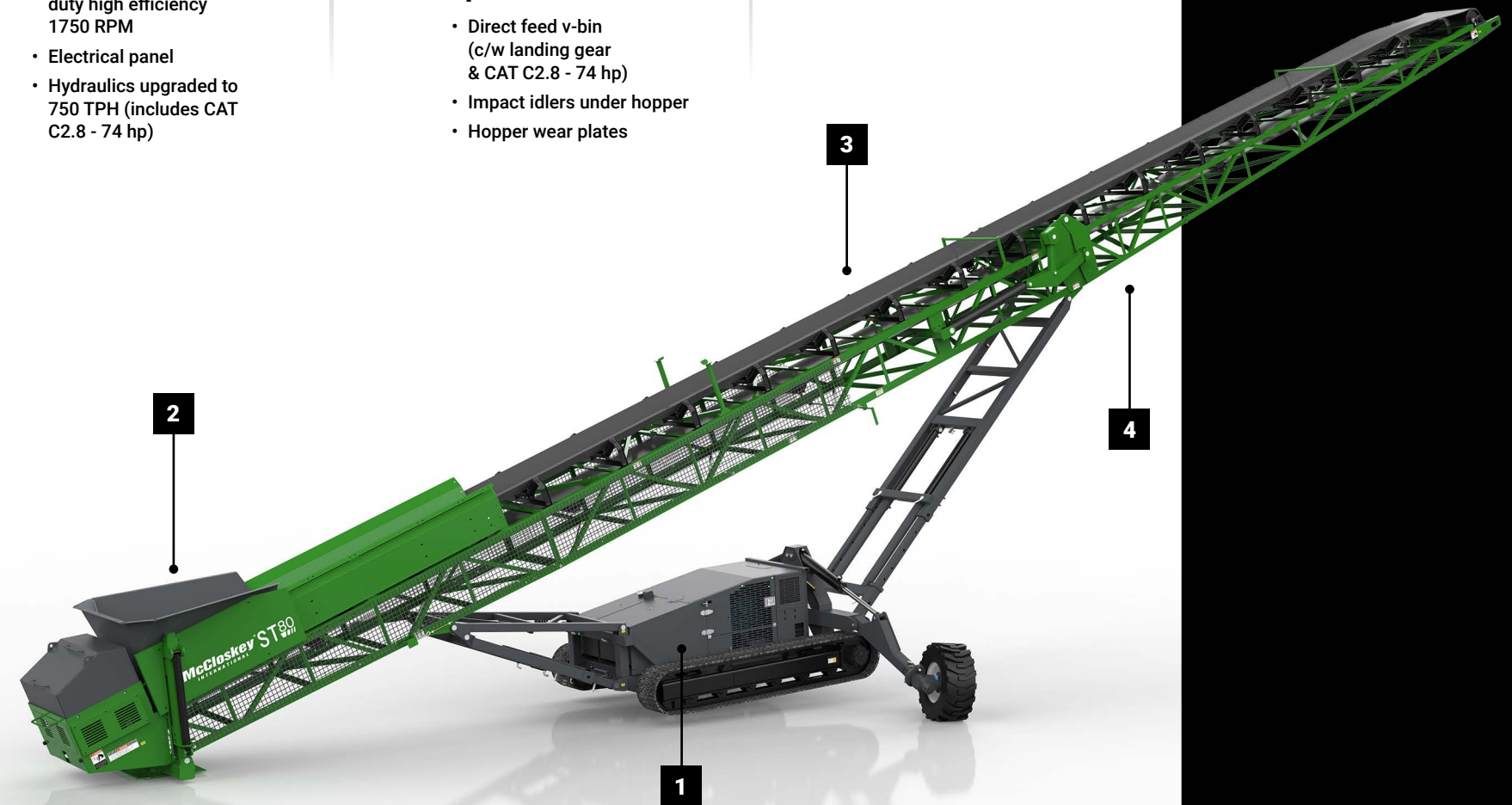

4 CONVEYORS

- Remote greaselines
- Counter weight design for higher stockpiling (ST80 = 100' conventional)

optional

- Reduce conveyor length to 65'
- Overband magnet on conveyor

OTHER FEATURES (OPTIONAL)

- Hydraulic axle jacks
- Hydraulic axle extensions
- Hydraulic landing gear
- Hydraulic wheel drive
- Spray bar
- Auxillary guarding
- Paddle wheel
- Upgraded belt cleaner/scrapper

SPECIFICATIONS

ADDITIONAL INFORMATION











CONVEYORS

SF80



 POWER PACK	CAT 3.6 100 KW (127 hp)
 HOPPER	17 yd ³ (13 m ³)
 DISCHARGE	31' 5" (9.6 m)

TRANSPORTATION	
 WEIGHT	54 000 lbs (24 500 kg)
 LENGTH	38' 8" (19.4 m)
 WIDTH	10' 6" (3.2 m)
 HEIGHT	11' 1" (3.4 m)

SPECIFICATIONS

- 1 POWER PACK**
- CAT 3.6 100KW (136 hp)
 - Dual hydraulic main drive system
 - Fuel efficient hydraulic system

- 2 HOPPER**
- Standard hopper 6' (1.8 m) width
 - Hopper extensions 9' (2.7 m) width
- optional**
- Mulch hopper
 - Aggregate hopper

- 3 BELT**
- 3 ply - 3/16 x 1/16 (57 mm x 19 mm)
- optional**
- 3 ply chevron

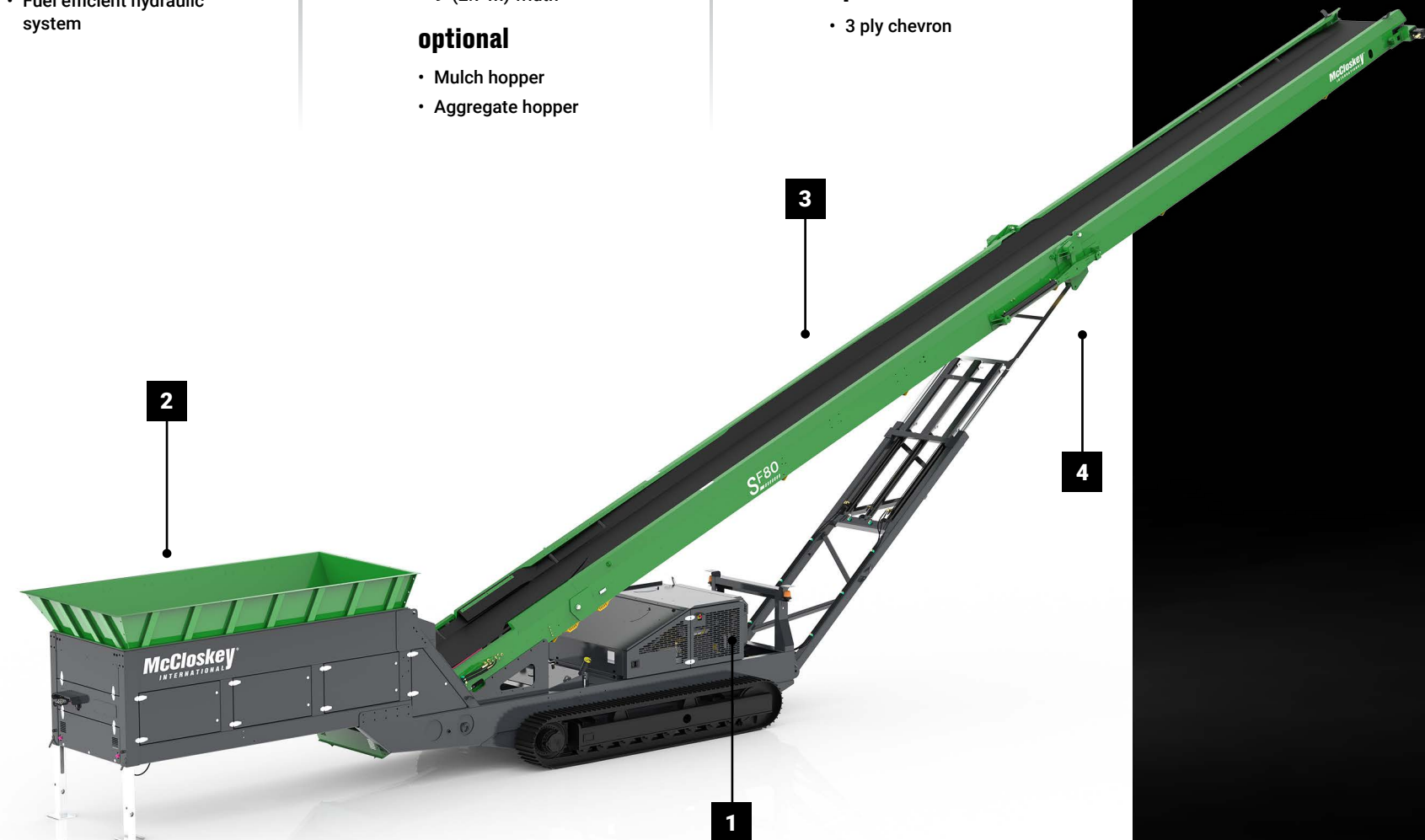

- 4 CONVEYORS**
- Remote greaselines
 - Hydraulic folding heading section for transport minimizing setup time
 - Hydraulically adjustable discharge height up to 31' 5" (9.6 m)
 - 48" (1.2 m) hot-spliced main conveyor
 - 48" (1.2 m) hot-spliced fee

- OTHER FEATURES (OPTIONAL)**
- Hydraulic tipping grid
 - Livehead
 - Hardox liners
 - Paddle wheel
 - Upgraded belt cleaner/scrapper

ADDITIONAL INFORMATION



INNOVATIVE ENVIRONMENTAL SOLUTIONS





SHREDDERS

INVENTHOR TYPE 6/9

The Inventhor Slow Speed Shredder Line employs high torque for reliable pre-shredding, featuring an effective drivetrain, intelligent material feed, and customizable shredding systems. Alongside the innovative VarioDirect Drive and efficient shredding system, the Inventhor integrates high-performance components, elevating it to a top-tier mobile shredder. These components enable unmatched throughput. The versatile INVENTHOR handles tasks like landfill volume reduction, waste incineration pre-shredding, and waste wood processing, thanks to its meticulously designed shredding concept.



SPECIFICATIONS

	INVENTHOR 6	INVENTHOR 6 PLUS	INVENTHOR 9
DRIVE			
Type	MTU 6R1000	CAT C9.3B	MTU 6R1300
Power	354 hp (264 kW)	415 hp (310 kW)	525 hp (391 kW)
CHASSIS			
Type	2-speed steel tracks	2-speed steel tracks	Tracklaying
Hopper loading height	10' 3" (3.2 m)	10' 3" (3.2 m)	11' 2" (3.4 m)
SHAFT			
Length	7' 2" (2.2 m)	7' 2" (2.2 m)	9' 10" (2.7 m)
Diameter	24" (610 mm)	24" (610 mm)	24" or 32" (610 or 810 mm)
Tooth configuration	15-tooth ²	15-tooth ²	21-tooth ³
Comb configuration tooth size	7" (174 mm)	7" (174 mm)	7" (174 mm)
Shredding system speed	30 RPM (2 RPM reverse)	30 RPM (2 RPM reverse)	32 RPM (5 RPM reverse)
CONVEYORS			
Rear length	23' (7 m)	23' (7 m)	23' (7 m) (28' (8.5 m) or 40' (12 m) options)
Rear width	48' (14.6 m)	48' (14.6 m)	48' (14.6 m)
Rear discharge height	9' 8" (2.5 m)	9' 8" (2.5 m)	16' (4.8 m)
Under length	9' 6" (2.5 m)	9' 6" (2.5 m)	16' (4.8 m)
Under width	32' (9.8 m)	32' (9.8 m)	40' (12 m)
TRANSPORT DIMENSIONS			
Length	25' 2" (7.5 m)	25' 2" (7.5 m)	32' 3" (9.8 m)
Width	8' 10" (2.7 m)	8' 10" (2.7 m)	9' 10" (2.8 m)
Height	11' (3.3 m)	11' (3.3 m)	12' 8" (3.9 m)
Total weight	53 000 lbs (24 000 kg)	53 000 lbs (24 000 kg)	77 000 lbs (34 900 kg)

OTHER FEATURES (OPTIONAL)

- Multiple tooth configurations
- Hopper extensions
- Selector screen
- Telematic monitoring system
- Quick-change shaft
- Magnetic head pulley
- Limiter system
- LED lighting system

¹ XL 6-tooth 24" shaft ;
L 8-tooth 24" shaft ;
M 26-tooth 32" shaft ;
S 36-tooth 32" shaft

² M 72-tooth (100 mm)
32" shaft

³ XL 14-tooth 250 mm ;
M 125-tooth (100 mm) ;
S 145-tooth (60 mm)

ADDITIONAL INFORMATION





GRINDERS

AK 315/565/640

The mobile fine shredders of the AK series are the ideal solution for compost or waste wood processors, disposal companies or the operators of biogas plants. Regardless of whether you process waste wood, RDF, offcuts, green waste, bio-waste, manure or pre-shred tree roots, the load-sensing infeed ensures a high throughput with maximum efficiency. Highly versatile and customizable, the AK series allows specific configurations such as shredding system adaptations, FE-fraction removal, hopper capacity increases, and a track-laying chassis for stability on rough terrain.



SPECIFICATIONS

	AK315	AK565 PLUS	AK565K	AK640SA	AK640K
DRIVE					
Type	MTU 6R 1000	MTU 6R 1300	MTU 6R 1300	MTU 6R 1500	MTU 6R 1500
Power	308 hp (230 kW)	523 hp (390 kW)	523 hp (390 kW)	617 hp (460 kW)	644 hp (480 kW)
CHASSIS					
Type	2-axle trailer	3-axle trailer	Steel tracks	Semi-trailer	Steel tracks
Hopper loading height	6' 7" (2 m)	7' 4" (2.2 m)	7' 3" (2.2 m)	7' 9" (2.4 m)	7' 2" (2.2 m)
MILL					
Width	57" (1.4 m)	69" (1.7 m)	69" (1.7 m)	69" (1.7 m)	69" (1.7 m)
Diameter	35" (900 mm)	44" (1.2 m)	44" (1.2 m)	44" (1.2 m)	44" (1.2 m)
# of hammers	16/28 (two rows)	36	36	36	36
Speed	1140 - 1320 RPM	850 -1000 RPM	850 -1000 RPM	970 -1140 RPM	970 -1140 RPM
CONVEYORS					
Rear length	19' 6" (5.9 m)	19' 6" (5.9 m)	24' 7" (7.5 m)	24' 7" (7.5 m)	24' 7" (7.5 m)
Rear width	59" (1.5 m)	70" (1.8 m)	60" (1.5 m)	60" (1.5 m)	60" (1.5 m)
Rear discharge height	11' 6" (3.5 m)	14' (4.2 m)	16' 7" (5 m)	17' 5" (5.3 m)	16' 7" (5 m)
TRANSPORT DIMENSIONS					
Length	30' 3" (9.2 m)	32' 8" (10 m)	28' 4" (7.5 m)	39' 3" (12 m)	32' 10" (10 m)
Width	6' 9" (2 m)	8' 2" (2.5 m)	9' 8" (3 m)	8' 3" (2.5 m)	9' 8" (3 m)
Height	10' 2" (3 m)	12' 5" (3.8 m)	11' 2" (3.4 m)	12' (3.6 m)	11' 2" (3.4 m)
Total weight	35 200 lbs (16 000 kg)	48 500 lbs (22 00 kg)	64 000 lbs (29 000 kg)	70 500 lbs (32 000 kg)	71 600 lbs (32 500 kg)

OTHER FEATURES (OPTIONAL)

- Neodymium magnet
- Various screen baskets
- Lowerable rear conveyor
- Magnetic head pulley
- Aggressive feed roller
- Dust suppression system
- Reinforced hopper
- Hopper extensions

ADDITIONAL INFORMATION





TROMMELS

SM 617/620/726

In the realm of separation technology, the Doppstadt SM series stands as a pioneer. Their trommels, powered by variable process technology, have set industry standards for decades, maintaining value, delivering consistent screening results over time, and thus securing an economic advantage for users. Thanks to hydraulic folding conveyors, the SM series drum screens are operational in less than five minutes. Each machine is precisely customizable to your needs, enabling fast and easy modifications.



SPECIFICATIONS

	SM 617.2	SM 720.2	SM 720.2 SA	SM 726.2 SA	SM 720.2 K
DRIVE					
Type	Duetz TCD 2.9 L4	Duetz TCD 3.6 L4	Duetz TCD 3.6 L4	Duetz TCD 3.6 L4	Duetz TCD 3.6 L4
Power	75 hp (55 kW)	114 hp (85 kW)	114 hp (85 kW)	114 hp (85 kW)	114 hp (85 kW)
CHASSIS					
Type	Central axle	Central axle	Fifth wheel, 2 axles	Fifth wheel, 2 axles	Steel tracks
Feed hopper	6.5 yd ³	6.5 yd ³	9.5 yd ³	9.5 yd ³	9.5 yd ³
Loading height	9' 6" (2.9 m)	9' 6" (2.9 m)	9' 6" (2.9 m)	9' 6" (2.9 m)	9' 6" (2.9 m)
DRUM					
Length	17' (5.2 m)	20' (6.1 m)	20' (6.1 m)	26' (6.1 m)	20' (6.1 m)
Diameter	6' (1.8 m)	7' (2.1 m)	7' (2.1 m)	7' (2.1 m)	7' (2.1 m)
Speed	0 - 21 RPM	0 - 21 RPM	0 - 21 RPM	0 - 21 RPM	0 - 21 RPM
CONVEYORS					
Side length	18' (5.5 m)	17' 3" (5.2 m)	18' (5.5 m)	18' (5.5 m)	17' 3" (5.2 m)
Side width	32" (0.8 m)	40" (1 m)	40" (1 m)	40" (1 m)	40" (1 m)
Rear length	18' (5.5 m)	18' (5.5 m)	18' (5.5 m)	18' (5.5 m)	18' (5.5 m)
Rear discharge height	32" (0.8 m)	40" (1 m)	40" (1 m)	40" (1 m)	40" (1 m)
TRANSPORT DIMENSIONS					
Length	36' 1" (11 m)	38' 9" (11.8 m)	38' 5" (11.7 m)	43' 5" (13.22 m)	42' (12.80 m)
Width	8' 4" (2.53 m)	8' 4" (2.53 m)	8' 2" (2.48 m)	8' 4" (2.53 m)	9' 8" (2.94 m)
Height	13' 1" (3.96 m)	13' 1" (3.96 m)	13' 2" (4.01 m)	13' 2" (4.01 m)	11' 2" (3.4 m)
Total weight	37 479 lbs (17 000 kg)	42 000 lbs (19 050 kg)	48 000 lbs (21 770 kg)	52 911 lbs (24 000 kg)	57 500 lbs (25 854 kg)

OTHER FEATURES (OPTIONAL)

- Tipping and vibrating grinders
- Multi-channel remote control
- Magnetic head pulleys
- Star screen insert
- Windsifter attachment
- Mulch coloring system
- Hopper extensions
- Bag rippers

ADDITIONAL INFORMATION





WINDROW TURNERS

A 30/38/50/55/60/65/75



Windrow turners by BACKHUS are the key component for organic material recyclers, whether for commercial, municipal sites, or farms use. With a wide range of models from the compact A30 to the powerful A75, our revolutionary composters adapt to each application, maximizing your compost production and saving space and time thanks to their innovative design.

SPECIFICATIONS

	A30	A38	A50	A55	A60	A65	A75
DRIVE							
Type	Yanmar	Cummins F3.8	Cummins B6.7	Cummins L9	Cummins X12	Cummins X12	Cummins X15
Power	54 hp (40 KW)	156 hp (115 KW)	280 hp (210 KW)	340 hp (250 KW)	400 hp (300 KW)	400 hp (300 KW)	600 hp (450 KW)
WINDROWS							
Width	up to 10' (3 m)	up to 12' 5" (3.8 m)	up to 16' 5" (5 m)	up to 18' (5.5 m)	up to 20' (6 m)	up to 21' 4" (6.5 m)	up to 24' 6" (7.5 m)
Height	up to 4' (1.2 m)	up to 6' 2" (1.9 m)	up to 7' 11" (2.4 m)	up to 8' (2.5m)	up to 9' (2.7 m)	up to 9' 10" (3 m)	up to 11' (3.3 m)
Capacity	900 yd ³ /h	2,000 yd ³ /h	5,200 yd ³ /h	5,900 yd ³ /h	6,500 yd ³ /h	6,500 yd ³ /h	8,900 yd ³ /h
DRUM							
Diameter	29" (0.7 m)	39.5" (1 m)	47" (1.19 m)	47" (1.2 m)	55" (1.2 m)	55" (1.4 m)	71" (1.8 m)
TRANSPORT DIMENSIONS							
Depth	4' 7" (1.4 m)	7' 5" (3.2 m)	8' 5" (2.5 m)	8' 5" (2.5 m)	9' 8" (2.9 m)	9' 8" (2.9 m)	11' (3.3 m)
Width	13' 8" (4.2 m)	18' 5" (5.6 m)	26' 3" (8 m)	27' 11" (8.5 m)	28' 6" (8.7 m)	33' 6" (10.2 m)	34' 9" (10.6 m)
Height	6' 3" (1.9m)	8' 6" (2.6 m)	10' 3" (3.1 m)	10' 3" (3.1 m)	11' 2" (3.4 m)	11' 10" (3.6 m)	12' 5" (3.8 m)
Total weight	4 100 lbs (17 000 kg)	14 100 lbs (6 395 kg)	31 000 lbs (14 061 kg)	38 000 lbs (17 236 kg)	45 000 lbs (20 411 kg)	53 000 lbs (24 040 kg)	68 000 lbs (30 844 kg)

OTHER FEATURES (OPTIONAL)

- Elevating cabin
- Irrigation connection
- Remote heated mirrors
- Landfill undercarriage
- Fleece winder
- Wheeled undercarriage
- Side conveyor
- Irrigation hose reel

¹ Fixed cabin model



ADDITIONAL INFORMATION





WINDROW TURNERS

SP 30/40/50/60

Drawing on 30 years of innovation, Menart windrow turners are renowned for their versatility in various applications such as green waste, dairy cattle manure, wastewater biosolids, and more. They are self-propelled and easy to control via a touchscreen, also recording technical data. Equipped with safety features like a radial torque limiter and a rubber safety curtain, these windrow turners easily fold into transport mode and are suitable for all terrains.



SPECIFICATIONS

	SP-30	SP-40	SP-50	SP-60
TRACTOR				
Required tractor	90 hp (67 KW)	110 hp (82 KW)	180 hp (134 KW)	250 hp (186 KW)
WINDROWS				
Width	11' (3.3 m)	14' 5" (4.4 m)	17' 8" (5.4 m)	21' (6.4 m)
Height	5' 6" (1.7 m)	5' 10" (1.8 m)	6' 6" (2 m)	7' 2" (2.2 m)
Height w/tunnel raised	7' 2" (2.2 m)	7' 6" (2.3 m)	8' 2" (2.5 m)	8' 6" (2.6 m)
PRODUCTIVITY				
Yards per hour	1 400 yd ³ /h	2 350 yd ³ /h	3 300 yd ³ /h	5 200 yd ³ /h

OTHER FEATURES (OPTIONAL)

- Camera system
- Water spray attachment
- Water tank attachment
- Windrow cover winder



ADDITIONAL INFORMATION





SCREENERS

2 FRACTION / 3 FRACTION

With exceptional flexibility and unmatched performance, Backers star screens efficiently break up material during the sizing process by creating intense agitation using durable polyurethane stars. This action can be advantageous compared to drum-style trommel screens or mesh-style deck screens when weather frequently impacts operations or affects source stockpiles. A range of models and options ensures a perfect fit in any application, in any environment, for any operation. Create two, three, or even four sized fractions in a single pass. Choose a tracked or wheeled chassis, or the only hybrid track/wheel chassis in the industry.



SPECIFICATIONS

	2 FRACTION	3 FRACTION
DRIVE		
Type	Perkins diesel	Perkins diesel
Power	188 hp (140 kW)	188 hp (140 kW)
Electrical system	24 V	24 V
CHASSIS		
Type	Tracked or wheeled options	Tracked or wheeled options
Feed hopper	6.5 yd ³	11 yd ³
Loading height	9' (3m)	11' 6" (3.5 m)
Track length	13' (4 m)	16' 6" (5 m)
Track width	16" (0.4 m)	16" (0.4 m)
CONVEYORS		
Fines length	17' (5.2 m)	12' 4" (3.7 m)
Fines width	26" (0.7 m)	26" (0.7 m)
Oversize length	12' (3.7 m)	N/A
Oversize width	48" (1.2 m)	N/A
Middle length	N/A	12' 4" (3.7 m)
Middle width	N/A	48" (1.2 m)
Unders length	N/A	19' 4" (5.9 m)
Unders width	N/A	48" (1.2 m)
STAR DECK		
Top deck length	22' (6.7 m)	16' 9" (5.1 m)
Top deck width	48" (1.2 m)	48" (1.2 m)
Top deck fraction size	3/8" – 6" (0.375 - 1.8 m)	1.5" – 8" (0.03 - 2.4 m)
Bottom deck length	N/A	22' (6.7 m)
Bottom deck width	N/A	48" (1.2 m)
Bottom deck fraction size	N/A	1/4" – 4" (0.25 - 0.10 m)

OTHER FEATURES (OPTIONAL)

- Tracks
- Wheels
- Track/wheel combination
- Deck slider
- Wind sifters
- Automatic deck cleaner
- Auger in hopper
- PU stars screens

ADDITIONAL INFORMATION





DENSITY SEPARATORS

AERAS / VENTUS

Discover the full range of density separators from Ecoverse, including the EcoSift Ventus 4 and the EcoSift AERAS. The Ventus 4 offers an innovative solution for removing contamination from excess compost without costly hydraulic separation, while the EcoSift AERAS enables low-cost removal of the light fraction. These technologies efficiently extract stone, paper, plastic, metal, and other inorganics from direct discharge streams, promoting the production of cleaner compost and maximizing revenue.



SPECIFICATIONS

	AERAS	VENTUS
DRIVE		
Type	Driven by an external machine	Volvo Penta TAD 57IVE
Power	N/A	174 hp (130 kW)
CHASSIS		
Type	N/A	Steel tracks
Loading height	N/A	11' 6" (3.5 m)
Track length	N/A	16' 6" (5 m)
Track width	N/A	16' (0.40 m)
CONVEYORS ¹		
Infeed width	N/A	60" (1.5 m)
Destoning width	N/A	60" (1.5 m)
Heavy fraction width	N/A	40" (1 m)
Heavy fraction height	N/A	7' (2.1 m)
SUCTION HOSE		
Diameter	19.5"	N/A
Length included	60"	N/A
SUCTION KNIFE		
Width ²	Extendable from 36" - 48" (0.90 m - 1.20 m)	N/A
TRANSPORT DIMENSIONS		
Length	72" (fan unit only) (1.8 m)	39' 6" (12 m)
Width	72" (fan unit only) (1.8 m)	9' 5" (2.9 m)
Height	65" (fan unit only) (1.6 m)	11' 2" (3.4 m)
Weight	approx. 3 000 lbs (1 360 kg)	37 479 lbs (16 864 kg)

OTHER FEATURES (OPTIONAL)

- Dual air filtration systems
- Full-access panel
- Secondary destoning belt
- Full CAN bus control
- Air hose integration
- Separation drum
- Triple suction fans
- Internal suction fan

¹ Belt has metal cleats to prevent material rolling back; magnetic head pulley and chute for ferrous recovery.

² SETUP : supports are bolted to the conveyor frame of the unit ; once frame is secured, the suction knife can be moved easily parallel or perpendicular to the belt to fine-tune the suction angle.

ADDITIONAL INFORMATION





DEPACKAGERS

HS 30/55/90

Tiger Depackaging Systems provides efficient solutions for separating organic waste from inorganic packaging, thereby converting food waste into profit! In a single operation, the Tiger can process waste, separate it, and extract organic waste into a wet or dry output, suitable for composting, animal feed, or AD biogas production. Additionally, it separates, cleans, and prepares packaging fractions such as paper, plastic, cardboard, aluminum, or metal for recycling.



SPECIFICATIONS

	HS 30	HS 55	HS 90
POWER			
Mill motor	30 kW	55 kW	90 kW
Feed motor	4 kW	7.5 kW	11 kW
Extraction motor	3 kW	3 kW	75.5 kW
Auxiliary motor	4 kW	4 kW	4 kW
TONNAGE			
Hopper capacity	2 yd ³	7 yd ³	7 yd ³
Tons per hour	up to 10	up to 20	up to 40
DIMENSIONS			
Total length	18' 4" (5.6 m)	24' (7.3 m)	26' (7.9 m)
Total width	6' 6" (2 m)	8' (2.4 m)	8' (2.4 m)
Hopper height	9' (2.7 m)	10' 6" (3.2 m)	10' 6" (3.2 m)
Total height	12' 8" (3.9 m)	13' 6" (4.1 m)	13' 6" (4.1 m)
ORGANIC DISCHARGE SYSTEM OPTIONS			
WET SYSTEM			
Slurry pump	11 kW	11 kW	11 kW
Organic tank auger	5.5 kW	5.5 kW	5.5 kW
DRY SYSTEM			
Organic auger	5.5 kW	5.5 kW	5.5 kW
DUAL SYSTEM			
Slurry pump	11 kW	11 kW	11 kW
Organic tank auger	5.5 kW	5.5 kW	5.5 kW
Organic auger	5.5 kW	5.5 kW	5.5 kW

OTHER FEATURES (OPTIONAL)

- Easy access
- Dry organic discharge
- Wet organic discharge
- Dual organic discharge
- Conveyors and auger
- Paper pulp recovery
- System integration
- Small footprint

ADDITIONAL INFORMATION





WASTES BALERS

SEMI-AUTOMATIC / TWO-RAM

CK International balers, renowned for their quality and exceptional performance, are available in two versions. Semi-automatic balers are perfectly suited for businesses generating significant volumes of waste, producing dense bales at an impressive rate of 3.3 tonnes per hour. Conversely, two-ram balers are ideal for waste transfer stations or sorting centers, offering high-density bales weighing up to 1.5 tonnes.



BENEFITS

- *OPTIMIZED BALING EFFICIENCY*
- *VERSATILE MATERIAL HANDLING*
- *FLEXIBLE TYING OPTIONS*
- *CUSTOMIZABLE DESIGN*
- *INTEGRATED MACHINERY COMPATIBILITY*
- *HIGH-CAPACITY PERFORMANCE*



ADDITIONAL
INFORMATION



TRANSFORMING MATERIALS TO VALUE









FEATURES

- INTELLIGENT OPERATING SYSTEM
- HIGH ENERGY MIXING CHAMBER
- LARGE VOLUME HOPPERS
- MATERIAL VOLUME SENSORS

PORTABLE BLENDING PLANTS

MAVERICK 224



	POWER PACK	CAT C3.6 134 hp (100 Kw)
	HOPPER	2 x 16 yd ³ (12 m ³)
	FEEDER BELTS	39" (1 m)
	PRODUCTION	Up to 1000 TPH

TRANSPORTATION

	WEIGHT	55 115 lbs (25 000 kg)
	LENGTH	40' 1" (12.2 m)
	WIDTH	9' 6" (2.9 m)
	HEIGHT	10' 4" (3.1 m)

ADDITIONAL
INFORMATION





OPTIONS

- FEED BOOT RUBBER LINERS
- HEAD SCRAPER UPGRADE
- ANTI-ROLL BACKS
- REAR HYDRAULIC FOLDING JACK LEGS
- EXTENDED FEED BOOT WITH MATERIAL SHELF
- HEAVY DUTY 4 PLY BELT

CONVEYOR

4065T



🔋	POWER PACK	CAT C2.2 74 hp (55 Kw)
🏠	BELT WIDTH	3 ply 40" (1 m)
▲	STOCKPILE HEIGHT	26' (7.6 m)

TRANSPORTATION

⚖️	WEIGHT	25 240 lbs (11 450 kg)
↔️	LENGTH	39' 9" (12.2 m)
↗️	WIDTH	7' 6" (2.3 m)
↑	HEIGHT	8' 3" (2.5 m)

ADDITIONAL INFORMATION



AULT

EXCLUSIVE DISTRIBUTOR

McCloskey
INTERNATIONAL

MWS 
EQUIPMENT

LIPPMANN





AULT

PERFORMANCE PARTS
SERVICE SUPPORT

WWW.AULT.CA INFO@AULT.CA
1.855.300.2858 (AULT)

JACKSON AULT

President
514.826.0925

ONTARIO

2000 Technology Drive
Peterborough (Ontario)
K9J 6X7

Sales 416.559.9832
Parts 705.957.0925
Service 705.313.5003

QUEBEC

30 rue Nadeau
Waterloo (Quebec)
J0E 2N0

Sales 514.826.0925
Parts 819.342.3023
Service 450.830.2492

MARITIMES

275 Price Street
Moncton (New-Brunswick)
E1A 2L2

Sales 902.452.1273
Parts 506.321.6895
Service 506.588.4846